



Model # 815PM5
POWERED MANUAL HORIZONTAL WINDER BANDER STRETCH
WRAP SYSTEM WITH VARIABLE TENSION



OPERATORS
MANUAL

Table of Contents

Warranty.....	3
Assembly.....	4
Film Loading.....	4-5
Operating Controls.....	5
Operating Instructions.....	5
Maintenance.....	6
Adjustments.....	6
Trouble Shooting.....	7
AC Drive Programming GS1.....	8
Ac Drive Programming AVT31...	9
Parts Lists.....	10-21
Wiring Diagram GS1.....	22
Wiring Diagram ATV31.....	23

Introduction

Congratulations! Your purchase of a Kalamazoo Series 800 Horizontal Winder Bander Stretch Wrap System will provide you with years of efficient stretch wrapping service. Your investment will ensure that your products will arrive cleaner, with less damage and pilferage at their destination at a lower cost to you.

Kalamazoo Packaging Systems products carry a LIMITED LIFETIME WARRANTY on all K.P.S. manufactured components; all parts not manufactured by Kalamazoo Packaging Systems will be subject to the original manufacturer's warranty.

Warranty

Kalamazoo Packaging systems, Inc. (KPS) agrees to furnish the purchaser, without charge, F.O.B. the factory, any part found to be defective in either material or workmanship within one (1) year from date of shipment, provided the purchaser gives immediate notice of any defect and description of that defect to KPS. KPS reserves the right to inspect any defective part to verify the defect and to determine probable cause of same.

The liability of KPS under this warranty is limited to furnishing replacements for defective parts, and unless otherwise agreed to in writing, the purchaser shall bear the expense of installation.

Failure of equipment or parts due to abuse, misuse, neglect, incorrect operating techniques or power line drops or surges shall not constitute failure because of defective material or workmanship, and are expressly excluded from this warranty.

The above is the only warranty with no other guarantees which extend beyond the above and the seller disclaims any implications including but not limited to a warranty of merchantability.

Assembly

Your Horizontal Winder has been assembled and tested at our manufacturing plant and released for shipment by a qualified technician. If the unit was shipped via common carrier or by our truck it may not be crated. **Any damage done in transit should be reported to the carrier immediately.** All our shipments are sent F.O.B. Grand Rapids, Michigan, therefore; the customer is responsible to settle any damage claims with the transportation company. Kalamazoo Packaging Systems will do everything possible to assist you in these matters.

The system shipped fully assembled. Plug the system into a 110/1/60Hz. 20 AMP. Outlet.

NOTE: The use of an extension cord may reduce the efficiency and life of the machine and is not recommended.

The System is now ready for operation.

Loading Film

Your wrapper is equipped with a Kalamazoo Variable Tension Film Delivery System. Place a roll of 5" stretch film on the film core holder and thread the film as shown on the diagram below. Once the film is loaded and the desire film tension is arrived at the film tension need not be adjusted again until the brand of film or the film thickness is changed.

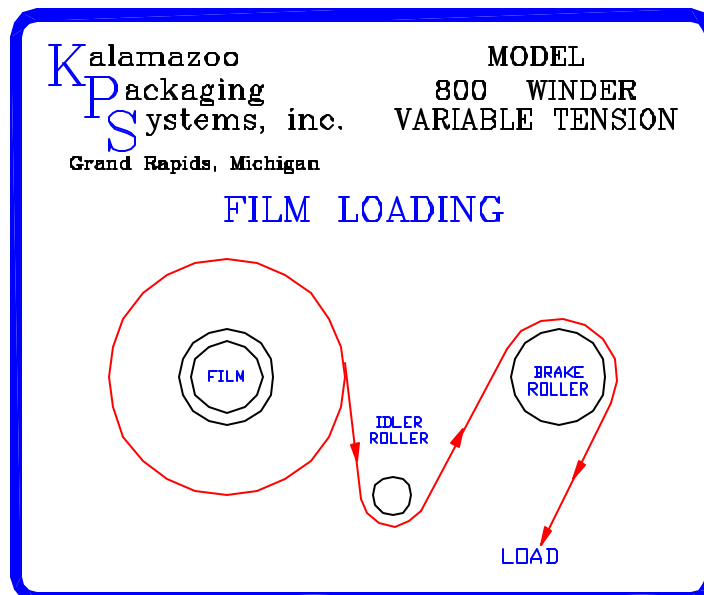

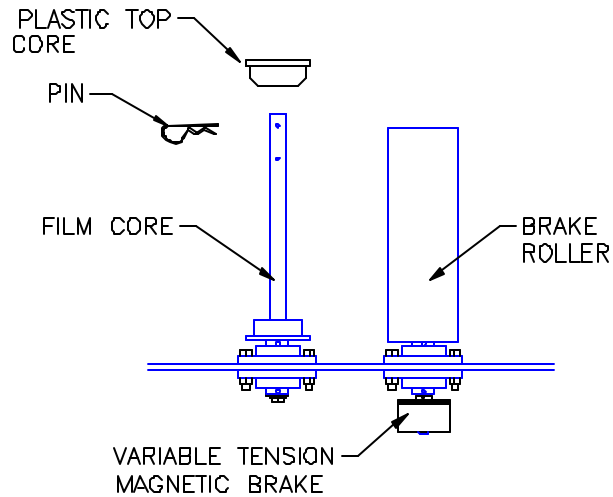

FILM LOADING AND TENSIONING

Place a roll of 5" film onto the film holder so the film unwinds clockwise, then slide the plastic top core into place and install the pin into the hole.

(note: The film core does not change the film tension.)

Thread the film as shown on the diagram.

Adjust the variable tension magnetic brake to the film tension you desire. Loosen the two set screws in the brake with a 5/64" allen wrench adjust the tension and retighten the set screws.

OPERATING CONTROLS

- 1 E-Stop push button.
- 2 Foot switch Control or selector switch.

OPERATING INSTRUCTIONS

- 1 Center the product over the Output Shelf Bridge, where you would like the band on the product.
- 2 Secure the film or hold on to it.
- 3 Push down on the Foot Switch.
- 4 After the product is wrapped. Let off of the Foot Switch.
- 4 After the Winder ring has stopped. Slide the product forward off of the Output Shelf Bridge and bring the product over to the cutter and cut the film.
- 6 End of wrap cycle.

GENERAL MAINTENANCE

Warning!!

MAKE SURE THAT POWER SUPPLY IS DISCONNECTED BEFORE ATTEMPTING TO SERVICE ANY COMPONENTS. IF THE POWER DISCONNECT IS OUT OF SIGHT, LOCK IT IN THE OPEN POSITION AND TAG IT TO PREVENT UNEXPECTED APPLICATION OF POWER.

Cleaning

Periodically clean dirt accumulations from machine, especially around moving parts and drive components, preferably by vacuuming.

General

- Check and tighten any loose fasteners.
- Check all electric connections and replace any worn or frayed cords.
- Check all fuses and breakers .

Lubrication

Bearings

- The bearings have been greased at the factory and are ready to run. It is recommended that all mounted bearings and support wheels be relubricated with #3 lithium base grease every three months.

Chains

- Clean, lubricate and adjust chains every month. Chain should be lubricated with a penetrating type commercial chain lube.

Gear Reducers

- For new reducers, change the oil 120 hours after the reducer starts operating (based on 8 hours per day of operation). After the first oil change, change oil every 2000 operating hours, or every six months, whichever occurs first.

Temperature	Lubricant
25° - 125° F	AGMA #8
15° - 60° F	AGMA #7

Certain conditions (dust, water, etc.) may require a change of lubricating periods as dictated by experience.

Adjustments

Wrap Start Soft-Start Acceleration - See page 8 for programming the AC drive

TOUBLESHOOTING

When any problem develops, review the operating instructions. Diagnose specific problems and review the options below.

Machine not running at all.

1. Check wall receptacle for power.
2. Check power cord for cut. (Fork Lift Trucks damage cords.)
3. Check all fuses and/or breakers.
4. Check AC drive for faults.
5. Check all limit switches for damage, sticking or internal shorts.
6. Open cabinet and check that all relays are firmly seated in their bases.
7. Visually inspect for loose wires and for any signs of arcing or burning of any of the components.
8. The film door must be shut before the winder will run.
9. Winder ring noises use taping wax around ring edge.
10. It is advisable to call for technical assistance at this time.

Technical and Customer Service is available from Kalamazoo Packaging Systems, Inc., Monday thru Friday 7:30 A.M. to 4:00 P.M. (EST). Stock is maintained on parts to allow us to ship the same day on most orders.

If you have a problem, we want to know about it! Please call and report any difficulties you may encounter.

- **Local - (616) 534-2600**
- **National - (800) 253-4625**

Telemecanique ATV11 AC Drive Programming

Winder- Telemecanique ATV11 AC Drive Programming

bFr Parameter

Code	Assignment	Setting
bFr	Motor Frequency	60

Settings Menu SEt-

Code	Assignment	Setting
ACC	Acceleration time	3.0
dEC	Deceleration time	3.0
HSP	High Speed	60.0
UFR	IR Compensation	50
SFR	Switching Frequency	2.0

Drive Control Menu drC

Code	Assignment	Setting
tUn	Auto-Tuning	Yes

I/O Menu I-O-

Code	Assignment	Setting
tCC	Conf. Terminal Block	2C

Display Menu Sup-

Code	Assignment	Setting
rFr	Output Frequency Applied	Enter

Kalamazoo
Packaing
Systems
Model #815PM5
Horizontal Winder Base

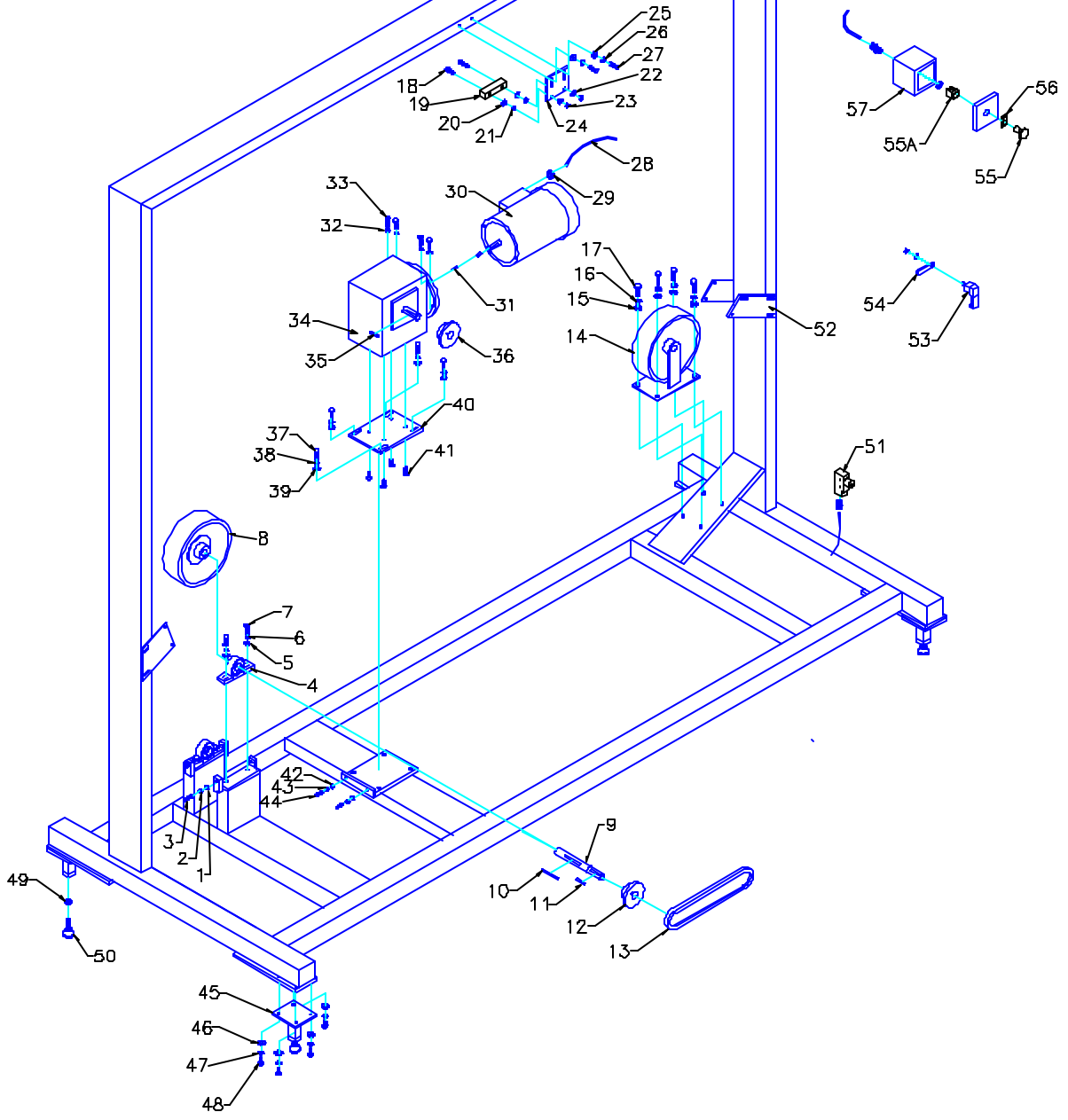

PARTS MANUAL: 815PM5 HORIZONTAL WINDER

ITEM	PART #	DESCRIPTION	QTY
1	F1017	5/16 SAE Washer	4
2	F1015	5/16 Lock Washer	4
3	F1090	5/16-18x 1-1/2" S.S.	4
4	1212500	1" Pillow Block Bearing	2
5	F1316	3/8 USS Washer	4
6	F1315	3/8 Lock Washer	4
7	F1335	3/8-16x 1-1/2" H.H.C.S.	4
8	1228060	10"x 3" Drive Wheel w/ Hub	1
9	815PM5-DS	Drive Shaft	1
10	F20x201/2	1/4"x 1/4"x 2-1/2" Keyway	1
11	F20x1	1/4"x 1/4"x 1" Keyway	1
12	1081180	Driven Sprocket 50BTL18	1
12	1081320	Bushing for above Sprocket	
13	1085000	# 50 Chain	1
14	1228000	10"x 3" Idler Wheel w/ Tapered Bearings	1
15	F1616	7/16 USS Washer	4
16	F1615	7/16 Lock Washer	4
17	F1635	7/16-14 x 1-1/2" H.H.C.S.	4
18	F1590	3/8-24 x 1-1/2" A.H.C.S.	12
19	2501000	800 Slide	6
20	F1016	5/16 USS Washer	12
21	F1506	3/8-24 Jam Nut	12
22	F1016	5/16 USS Washer	12
23	F1506	3/8-24 Jam Nut	12
24	2501010	800 Slide Holder	6
25	F1316	3/8 USS Washer	12
26	F1315	3/8 Lock Washer	12
27	F1513	3/8-24x 1-1/4" H.H.C.S.	12
28	2099050	14/4 STO Cord	1
29	2103400	Cord Grip	1
30	1053420	1-1/2hp. 230-460/3/60hz. Super-E 140TC	1
31	F10x3/4	3/16"x 3/16"x 3/4" Keyway	1
32	F1315	3/8 Lock Washer	4

PARTS MANUAL: 815PM5 HORIZONTAL WINDER

ITEM	PART #	DESCRIPTION	QTY
33	F1333	3/8-16 x 1" H.H.C.S.	4
34	1065952	5:1 R/A Reducer 1.75CD 145TC Face	1
35	F20x1	1/4"x 1/4"x 1" Keyway	1
36	1081200	820FAC-20 Winder Drive Sprocket 50BTL20	1
36	1081320	Bushing for above Sprocket	1
37	F1335	3/8-16 x 1-1/2" H.H.C.S.	4
38	F1315	3/8 Lock Washer	4
39	F1316	3/8 USS Washer	4
40	820FA20-AHD-MMSP	800 Motor Mount	1
41	F1051	5/16-18 x 1" F.H.	4
42	F1016	5/16 USS Washer	2
43	F1015	5/16 Lock Washer	2
44	F1090	5/16-18x 2" S.S.	2
45	800-RFM	Winder Rubber Foot Mounting	4
46	F1316	3/8 USS Washer	16
47	F1315	3/8 Lock Washer	16
48	F1333	3/8-16 x 1" H.H.C.S.	16
49	F1900	1/2-13 Nut	4
50	1228510	1/2-13 Rubber Foot	4
51	2108520	Limit Switch (Plunger)	1
52	815PM5-LSH	Lower Limit Switch Plate	4
53	6238000	Lift & Turn Latch	1
54	6238001	Lift & Turn Latch Plate	1
55	2064000	22mm E-STOP (Push/Pull)	1
55A	2072000	1 N.C. Contact Block	1
56	2074500	22mm E-STOP Legend Plate	1
57	A-404SC	Push Button Enclosure	1
		Optional Caster and Floor Locks	
	1222600	4" Swivel Caster (not shown)	4
	1293200	4" Floor Lock (not shown)	4

Kalamazoo Packaging Systems
 Model #800PM-RING
 Variable Tension Ring
 w/ Pined Top Core

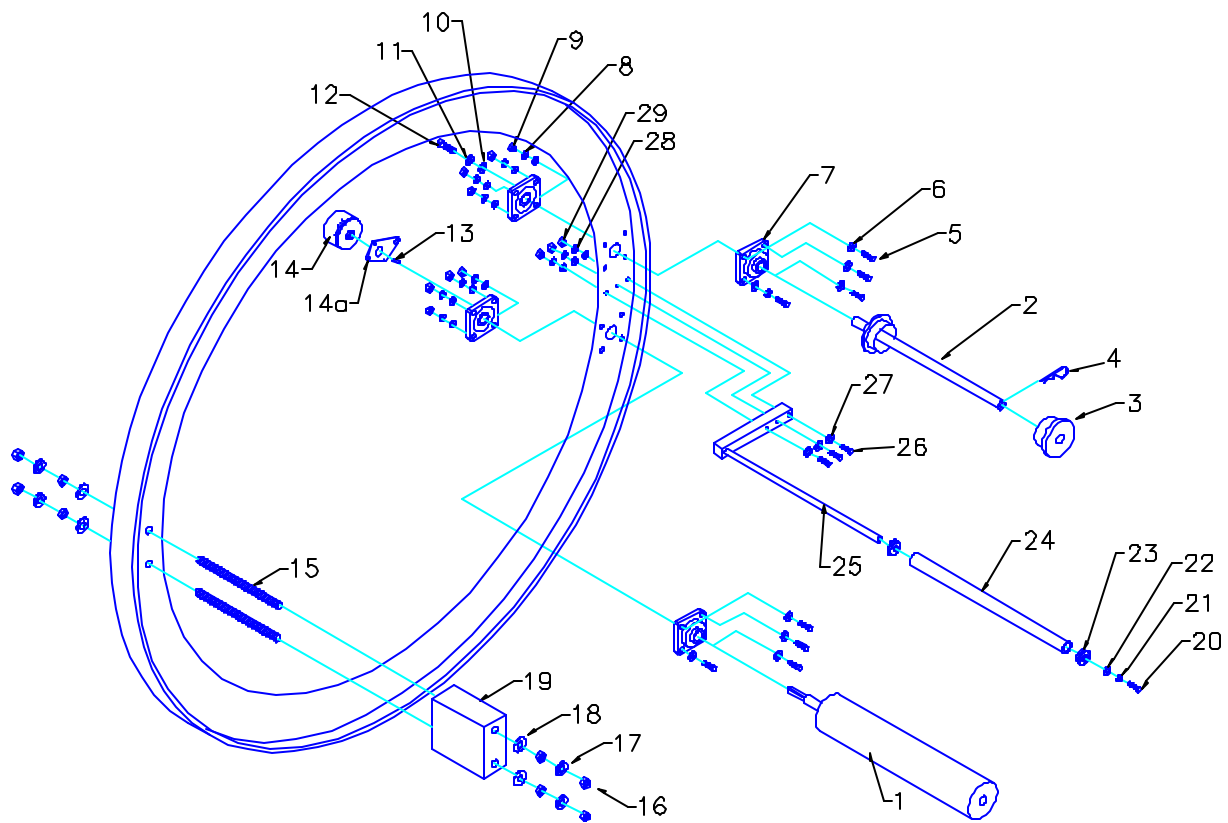

PARTS MANUAL: 815PM5 WINDER RING

ITEM	PART/DWG.#	DESCRIPTION	QTY
1	800v-5-BR	4" DIA. x 5" Winder Tension Roller	1
2	800v-5.25-CORE-P	5-1/4" Winder Film Core w/ Pined Top Core	1
3	6230780	3" Plastic Top Core	1
4	6230790	3/16" Hitch Pin Clip	1
5	F1817	7/16-20 x 2-1/4" H.H.C.S.	8
6	F1617	7/16 SAE Washer	16
7	121140	1" 4-Bolt Flange Bearing	4
8	F1615	7/16 Lock Washer	8
9	F1605	7/16-20 Nylock Nut	8
10	F1916	1/2" USS Washer	1
11	F1915	1/2" Lock Washer	1
12	F1933	1/2-13 x 1" H.H.C.S.	1
13	F10x3/4	3/16" x 3/16" x 3/4" Keyway	1
14	1305500	5/8" Finish Bore Magnetic Brake (MC 4)	1
14A	800v-MC4-BM	MC4 Brake Mount	1
15	F2880x9	3/4-10 x 9.0" Threaded Rod	4
16	F2800	3/4-10 Nut	16
17	F2815	3/4" Lock Washer	8
18	F2816	3/4" USS Washer	8
19	815PM5-CW	Counter Weight	2
20	1033	5/16-18x 1" H.H.C.S.	1
21	F1015	5/16" Lock Washer	1
22	F1016	5/16" USS Washer	1
23	1206000	5/8" I.D. x 1-3/8" O.D. Flange Bearing	2
24	5371250	1-1/4 PVC Tube sch.40 x 5-3/4"	1
25	815PM5-BIR	Film Tension Idler Roller Mount	1
26	F1037	5/16-18x 2" H.H.C.S.	2
27	F1017	5/16" SAE Washer	4
28	F1015	5/16" Lock Washer	2
29	F1005	5/16-18 Nylock Nut	2

Kalamazoo Packaging Systems
 Model # 815PM5
 Input Gravity Roller Conveyor

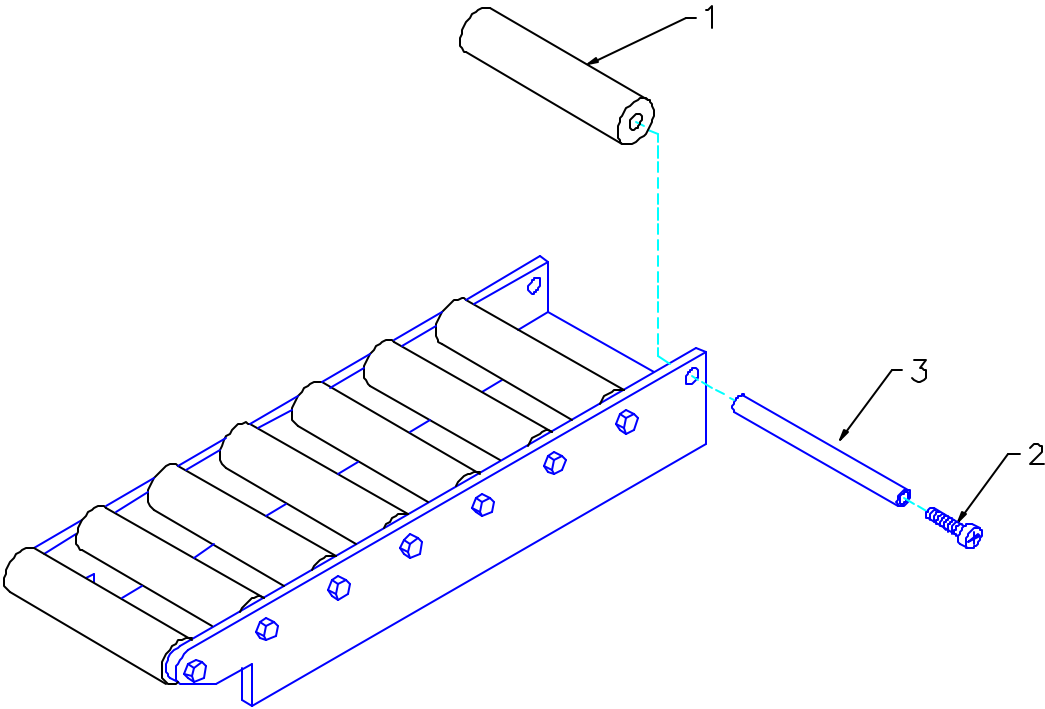

PARTS MANUAL: 815PM5
INPUT GRAVITY ROLLER CONVEYOR

ITEM	PART/DWG.#	DESCRIPTION	QTY
1	815PM5-F5b	1" DIA. x 4-1/8" UHMW Roller	8
2	815PM5-F5c	3/8" Shaft x 4-9/16 Tap Both End 1/4-20x 7/8"	8
3	F740	1/4-20x 3/4" B.H.S.C.S	16

Kalamazoo Packaging Systems
 Model # 815PM5
 Output Shelf with Bridge

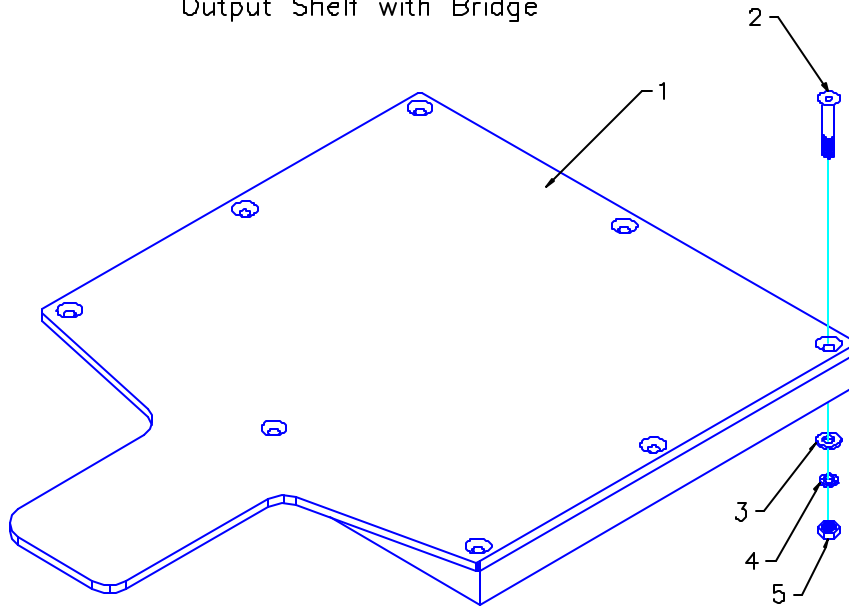

PARTS MANUAL: 815PM5
OUTPUT SHELF with BRIDGE

ITEM	PART/DWG.#	DESCRIPTION	QTY
1	815PM5-F6a	Output Shelf with Bridge Plate	1
2	F753	1/4-20x 1-1/2" F.H.	8
3	F722	1/4 SAE Washer	8
4	F720	1/4 Lock Washer	8
5	F700	1/4-20 Nylock Nut	8

Kalamazoo Packaging Systems
 Model # 815PM5
 Control Cabinet

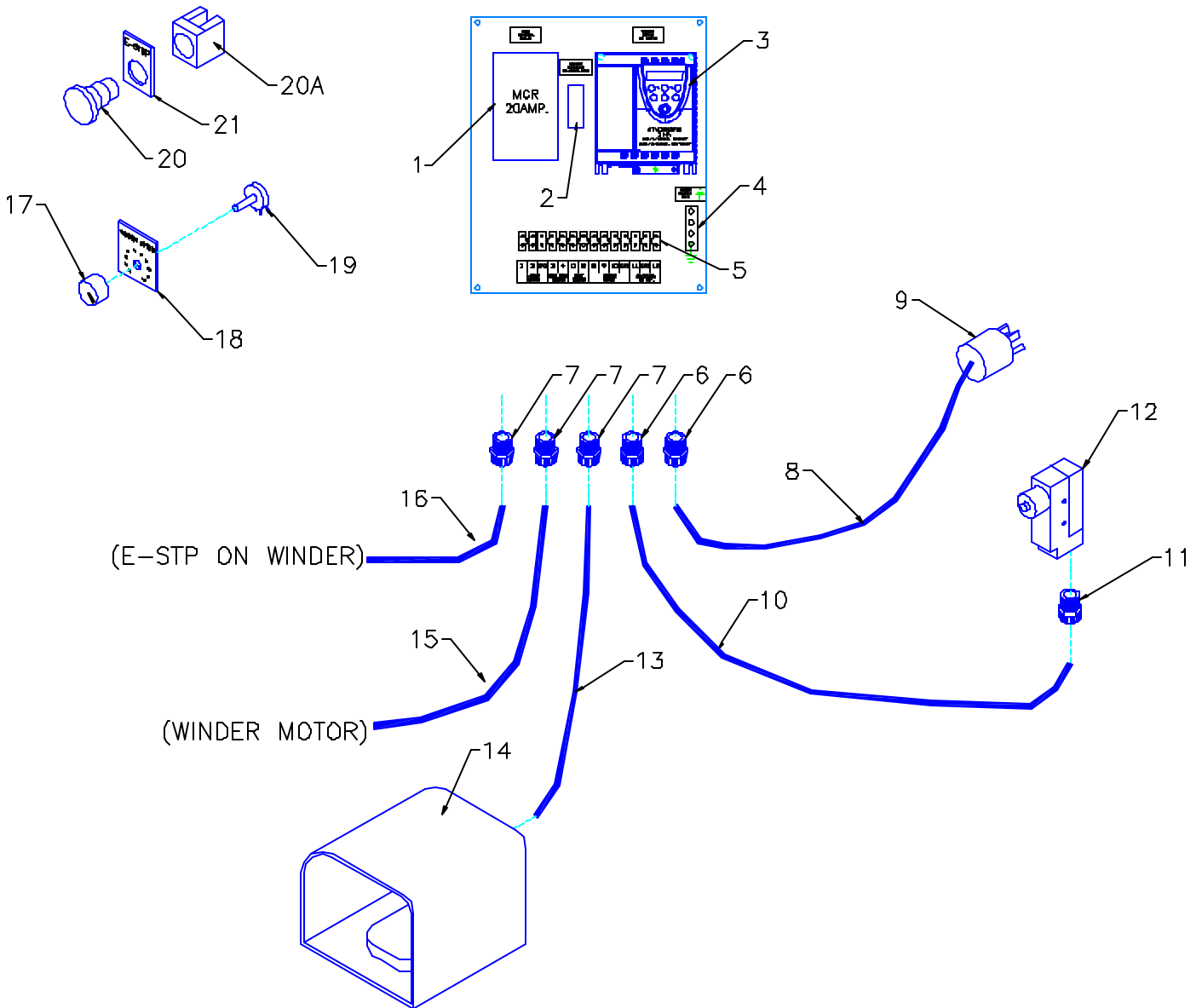

**PARTS MANUAL:
815PM5 HORIZONTAL WINDER CONTROL BOX
with Telemecanique AC Drives and Breakers**

ITEM	PART #	DESCRIPTION	QTY
1	2080800	20 AMP. Main Control Relay (110v Coil)	1
2	2112010	20 AMP. 1-Pole Breaker	1
3	1318505	AC Drive 1hp. 110/1/60 IN 230/3/60 OUT	1
4	2104360	Ground Bus	1
5	209700	12 Terminal Strip	1
6	2103572	1" Cord Grip	2
7	2103571	3/4" Cord Grip	3
8	2099100	12/3 SJ Cord x 12'	1
9	2101520	Cord Cap 20 AMP. (5-20P)	1
10	2098500	16/3 SJ Cord Limit Switch	1
11	2103571	3/4" Cord Grip	3
12	2108520	Limit Switch (Plunger)	1
13	2098500	16/3 SJ Cord Foot Switch	1
14	2107100	Foot Switch Guard	1
14	2107000	Foot Switch	1
15	2099050	14/4 STO Motor Cord (Yellow)	1
16	2098500	16/3 SJ Cord E-STOP on Winder	1
17	1311990	Controller Knob 1/4"	1
18	2069110	Winder Ring Speed Dial Legend	1
19	1312050	10K Potentiometer	1
20	2064000	22mm E-STOP (Push/Pull)	1
20A	2072000	1 N.C. Contact Block	1
21	2074500	22mm E-STOP Legend Plate	1

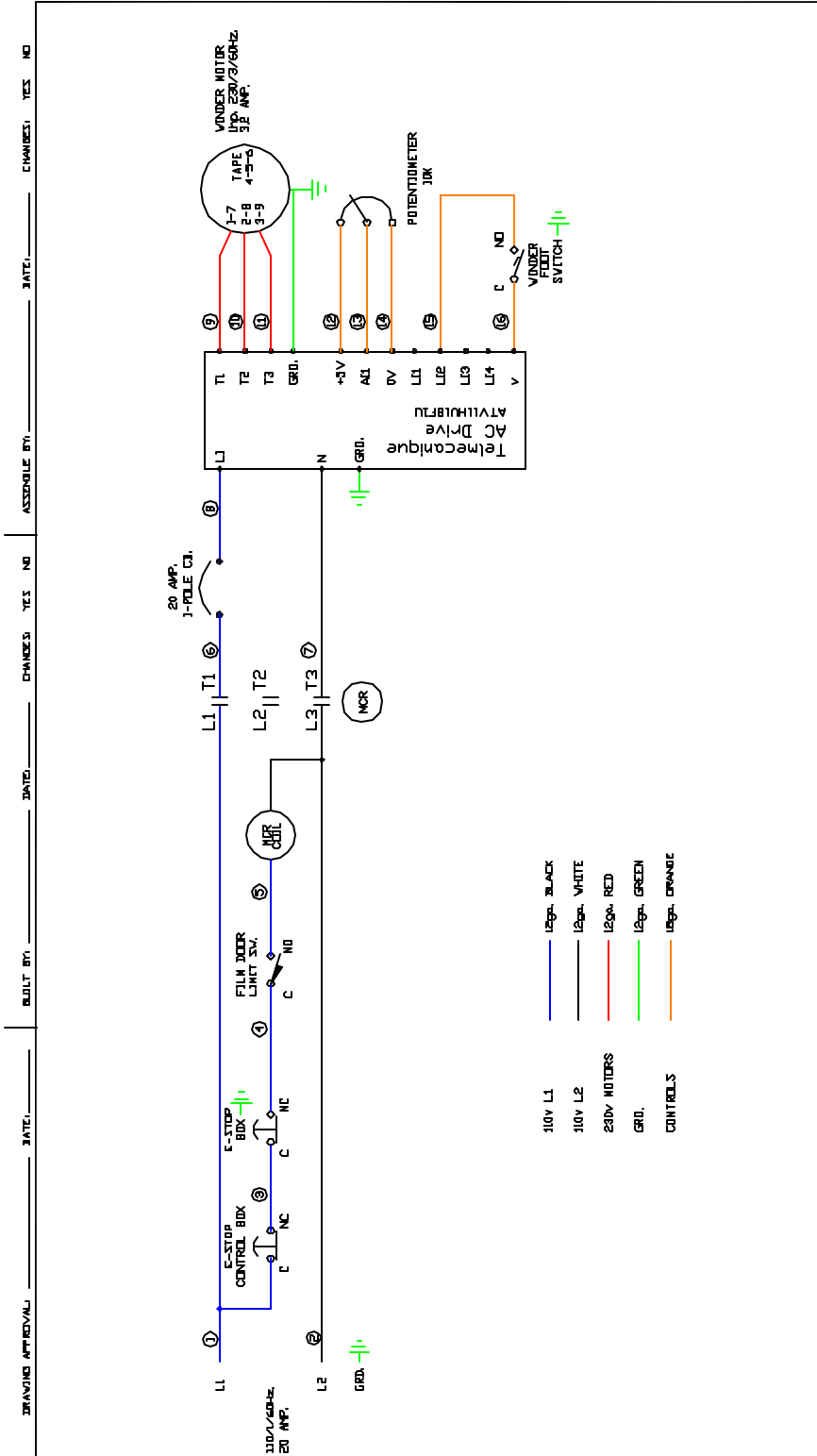

 <p style="text-align: center;">Kalamazoo Packaging Systems, Inc. Grand Rapids, Michigan</p>	<p>Name: 815PM5 VINDER WIRING DIAGRAM</p> <p>Date: 04/19/2010</p> <p>Drawn By: Ty Ferris</p>	<p>Dwg.No.: W-815PM5</p> <p>Rev. Date:</p> <p>Rev. By:</p>
THESE DRAWINGS OR PORTIONS THEREOF ARE UNCLASSIFIED AND RELEASE TO THE PUBLIC ON THE AUTHORITY OF THE NATIONAL ARCHIVES AND RECORDS ADMINISTRATION		