



**MODEL 998CSA
CONVEYORIZED STRETCH
WRAP SYSTEM**



**OPERATOR'S
MANUAL**

Table of

Contents

Introduction.....	3
.....	
Warranty.....	3
Getting Started.....	4
Film Loading.....	4
Machine Layout.....	5-6
Stretch Wrapper Console.....	7
Upeuder Console.....	7
End Table Console.....	8
Operating Instructions.....	8
Program Controls.....	9
Maintenance.....	9
Trouble shouting.....	9
Customer Service.....	10
Parts Manual.....	11-29
Wiring Diagram.....	30-32
Allen-Bradley PLC Program.....	33-74

Introduction

Congratulations! Your purchase of a Kalamazoo Model 998CSA Stretch Wrap System will provide you with years of efficient spiral stretch wrapping of your product. Your investment will ensure that your products will arrive cleaner, with less damage and pilferage at their destination at a lower cost to you.

Kalamazoo Packaging Systems products carry a LIMITED LIFETIME WARRANTY on all K.P.S. manufactured components; all parts not manufactured by Kalamazoo Packaging Systems will be subject to the original manufacturer's warranty.

Warranty

Kalamazoo Packaging systems, Inc. (KPS) agrees to furnish the purchaser, without charge, F.O.B. the factory, any part found to be defective in either material or workmanship during the warranty period, provided the purchaser gives immediate notice of any defect and description of that defect to KPS. KPS reserves the right to inspect any defective part to verify the defect and to determine probable cause of same.

The liability of KPS under this warranty is limited to furnishing replacements for defective parts, and unless otherwise agreed to in writing, the purchaser shall bear the expense of installation.

Failure of equipment or parts due to abuse, misuse, neglect, incorrect operating techniques or power line drops or surges shall not constitute failure because of defective material or workmanship, and are expressly excluded from this warranty.

The above is the only warranty with no other guarantees which extend beyond the above and the seller disclaims any implications including but not limited to a warranty of merchantability.

Getting started!

The machine will need to be placed on the floor per drawing # 998-ALL and 998-ALL-S. All conveyor, turntable, sensors, hyd. Power unit, upender, and tower will need to be wired into the main control enclosure and 460/3/60HZ. 40 amp. Power supply. Once the machine is up and running it will need to be aligned, leveled, plumbed and bolted to the floor.

Film Loading

Your wrapper is equipped with our Kalamazoo Variable Tension Film Delivery System. Place a roll of 20" stretch film on the film core holder and thread per diagram below or on top of the film head.

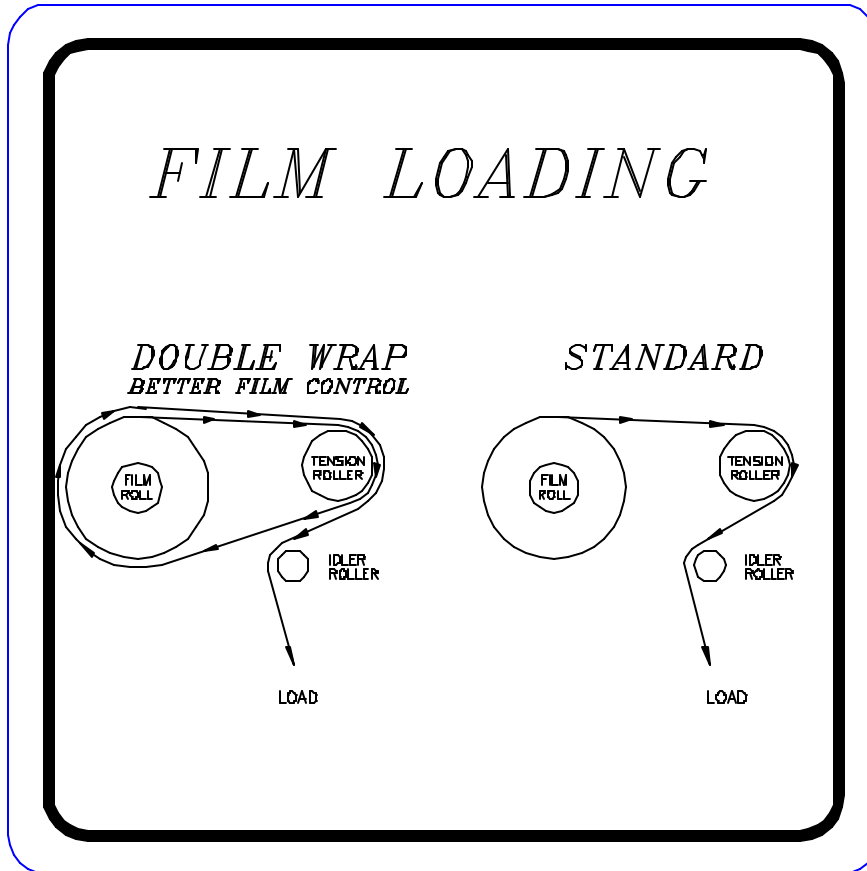

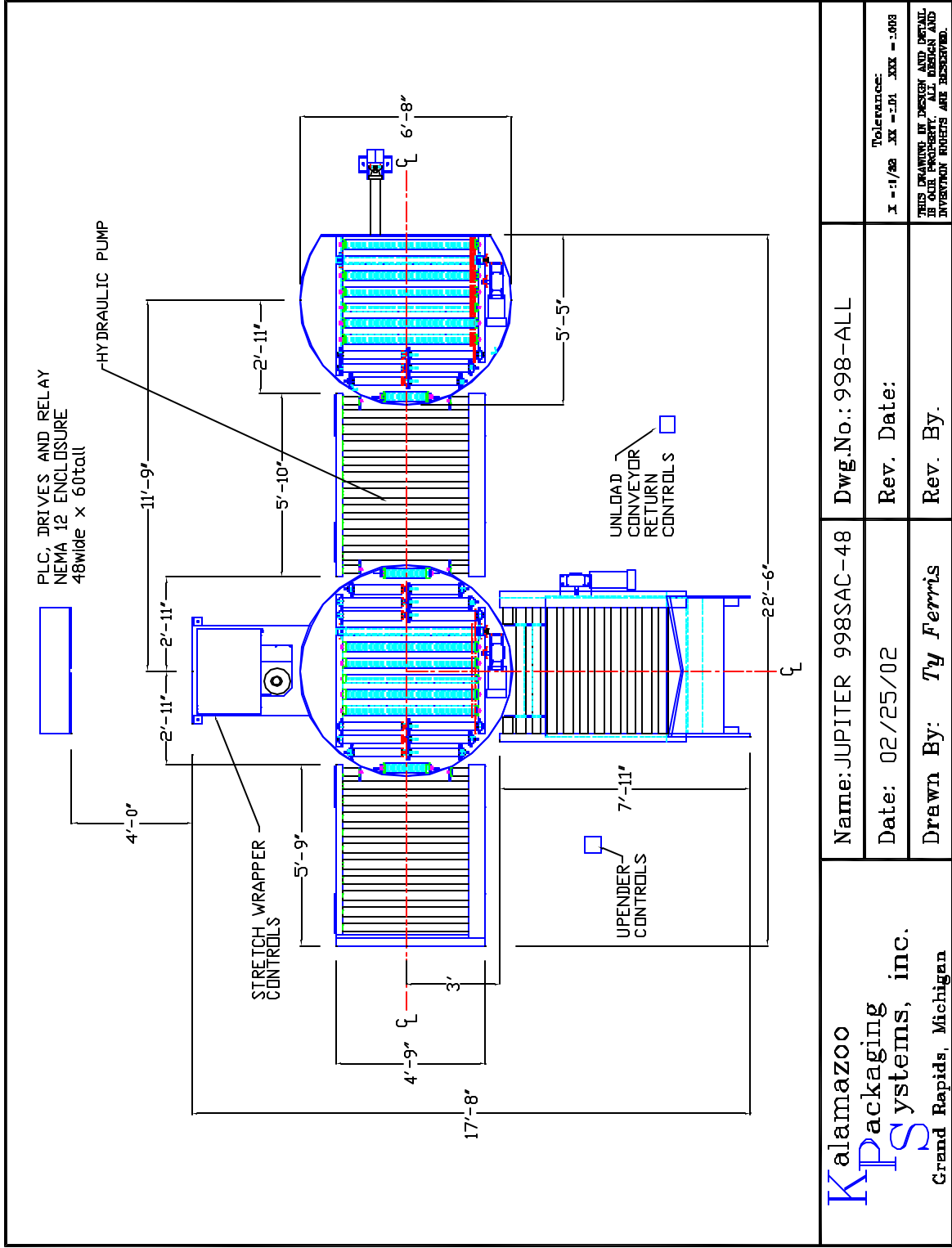

Kalamazoo
KPackaging
PSystems, inc.
 Grand Rapids, Michigan

Name: JUPITER 998SAC-48
 Date: 02/25/02
 Drawn By: Ty Ferris

Dwg.No.: 998-ALL
 Rev. Date:
 Rev. By:

Tolerance:
 X = ±1/32 XX = ±.01 XXX = .008
 THIS DRAWING IS DESIGN AND DETAIL
 IN OUR PROPERTY. ALL DESIGN AND
 INVENTION RIGHTS ARE RESERVED.

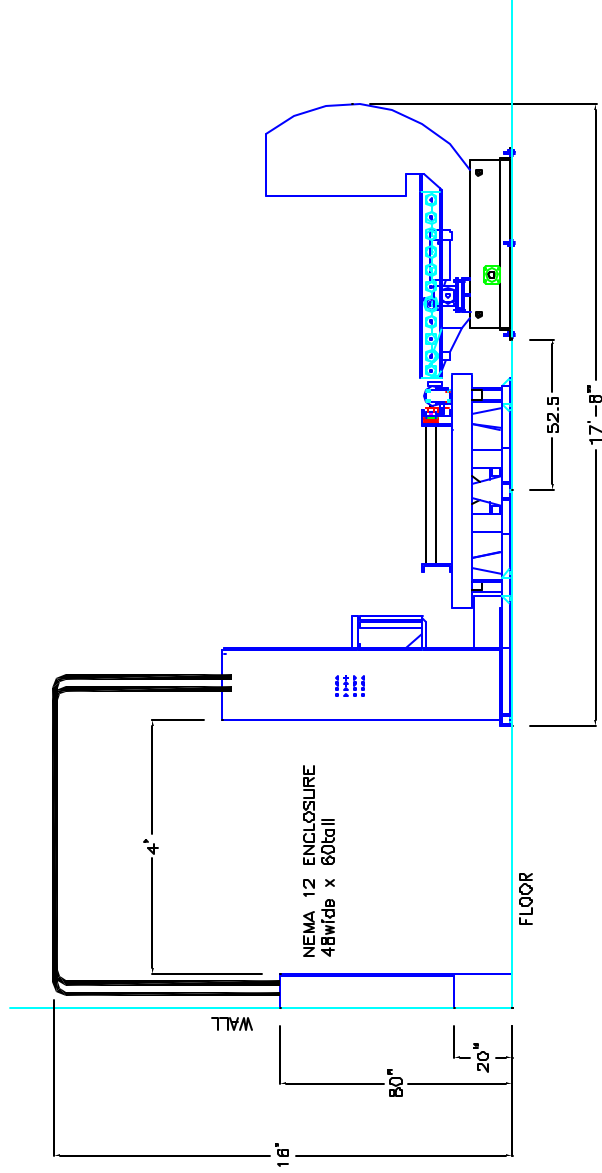

Kalamazoo
KPS packaging systems, inc.
 Grand Rapids, Michigan

Name: JUPITER 998SAC-48

Dwg.No.: 998-ALL-S

Date: 02/25/02

Rev. Date:

Drawn By: Ty Ferris

Rev. By:

Tolerance:

X -1/32 XX -1/64 XXX -1/32

THIS DRAWING IS DESKTOP AND PRINTED IN OUR PROPERTY. ALL DESIGN AND INVENTION RIGHTS ARE RESERVED.

STRETCH WRAP CONSOLE

POWER ON– Turns system on.

POWER OFF– Turns system off.

E-STOP - Shuts off system, stops cycle and resets timers and counters.

CYCLE START - System is now ready to start loading the product.

CYCLY INTERRUPT– Interrupts the system. But does not reset timers and counters.

HOME– Reset the stretch wrapper film carriage to the bottom sensor and reset the turntable to home position.

WRAP CYCLE START– Starts the stretch wrap cycle.

PROGRAM

1 BAND/ 2 BANDS/WRAP ONLY–

1 Band = Product is stretch wrapped and the turntable will stop so the employee can put one band around the product. After Banding push the CYCLE START button and the turntable will return to he home position.

2 Bands = Product is stretch wrapped and the turntable will stop so the employee can put one band around the product. After banding push the CYCLE START button and the turntable will turn 45 deg. and stop so the employee can put the second band around the product. After the band push the CYCLE START button and the turntable will return to he home position.

WRAP ONLY= Product is stretch wrapped only.

WRAP CYCLE INTERRUPT– Stop only the wrap cycle. Will not reset timers or counters in the wrap cycle.

WRAPPER UNLOAD– After the product is stretch wrapped and banded. Push WRAPPER UNLOAD to unload the stretch wrapper turntable conveyor.

FILM LIFT

RAISE/AUTO/LOWER– Manual raise and lowers the film.

UPENDER CONV.

FWD/AUTO/REV. – Manual turn on the upender conveyor.

INPUT #2 CONV.

FWD/AUTO/REV. – Manual turn on the input #2 conveyor.

TABLE CONV.

FWD/AUTO/REV. – Manual turn on the turntable conveyor.

OUTPUT #1 CONV.

FWD/AUTO/REV. – Manual turn on the output #1 conveyor.

END TABLE CONV.

FWD/AUTO/REV. – Manual turn on the end table conveyor.

TABLE JOG– Manual runs the stretch wrapper turntable.

UPENDER CONSOLE

E-STOP - Shuts off system, stops cycle and resets timers and counters.

CYCLE START - System is now ready to start loading the product.

CYCLY INTERRUPT– Interrupts the system. But does not reset timers and counters.

UPENDER LOAD-Moves the upender so it can be loaded with the product. This is a momentary push button so the upender can only be run if the employee is at a safe distains.

UPENDER UNLOAD-Moves the upender so the product can be unloaded onto the stretch wrapper. This is a momentary push button so the upender can only be run if the employee is at a safe distains.

WRAPPER LOAD– Moves the stretch wrapper turntable inline with the upender if it is not in the stretch wrapping program and turns on the upender conveyor and the stretch wrapper turntable conveyor and loads the product.

END TABLE CONSOLE

E-STOP - Shuts off system, stops cycle and resets timers and counters.

CYCLE START - System is now ready to start loading the product.

CYCLY INTERRUPT– Interrupts the system. But does not reset timers and counters.

END TABLE UNLOAD-Moves the end table conveyor to the unload position.

END TABLE LOAD-Moves the end table to the load position.

OPERATING INSTRUCTIONS

- 1 Turn the disconnect to on.
- 2 Push the POWER ON button. The button will light up and the system is ready to run.
- 3 Load the upender with the product and push the UPENDER UNLOAD button .
- 4 Push the WRAPPER LOAD button. If the stretch wrapper is not in a cycle the stretch wrapper turntable will come on and move to the upender. The stretch wrapper conveyor and the upender conveyor will come on and move the product onto the stretch wrapper conveyor and center it.
- 5 Attach the film to the product and select the wrap program. Push the WRAP CYCLE START button. If program 1 BAND is selected the stretch wrapper turntable will come on and put two reinforcing wraps on the bottom of the product. The film carriage will come on and move to the top of the product and stop and it will place two reinforcing wraps to the top on the product and return to the bottom. The stretch wrapper turntable will decal and stop so the employee can put one band on the product. After banding push the WRAP CYCLE START button and the stretch wrapper turntable will return to the home position.
- 6 Place the stickers or labels onto the product and push the WRAPPER UNLOAD button.
- 7 If PROGRAM -2 BANDS is selected after the first band is applied push the WRAP CYCLE START button and the stretch wrapper turntable will come on a move 45 deg. And stop so the employee can applie the second band after the second band is applied push the WRAP CYCLE START button and the stretch wrapper turntable will return to the home position.
- 8 Place the stickers or labels onto the product and push the WRAPPER UNLOAD button.
- 9 If program WRAP ONLY is selected the product will be wrapped only. The stretch wrapper turntable will stop at the home position.
- 10 Place the stickers or labels onto the product and push the WRAPPER UNLOAD button.

Allen-Bradley PCL: See manufacturer's manual.

Lift Speed: Varies the film carriage speed, changing the amount of film overlap. See manufacturer's manual.

Turntable Speed: Varies the speed of the turntable, which varies the wrap cycle time and the film overlap. See manufacturer's manual.

Film tension : Varies the film tension .

Conveyor Speed: Varies the speed of the conveyors. See manufacturer's manual.

Maintenance

WARNING: MAKE SURE THAT POWER SUPPLY IS DISCONNECTED BEFORE ATTEMPTING TO SERVICE ANY COMPONENTS. IF THE POWER DISCONNECT IS OUT OF SIGHT, LOCK IT IN THE OPEN POSITION AND TAG IT TO PREVENT UNEXPECTED APPLICATION OF POWER.

CLEANING

Periodically clean dirt accumulations from machine, especially around moving parts and drive components, preferably by vacuuming.

GENERAL

Check and tighten any loose fasteners.

Check all electrical connections and replace any worn or frayed cords.

Troubleshooting

Machine not running

When any problem develops, review the operating instructions. Diagnose specific problems and review the options below.

- ✓ Check wall receptacle for power.
- ✓ Check Power cord for cut. (Fork Lift Trucks damage cords.)

Check turntable sensor to make they are working.

System does not automatically stop

- ⓘ Push E-STOP button to clear the system and than push the HOME button. Try operating it again.

DISCONNECT POWER FROM MACHINE

- ✓ Check both top and bottom film sensor switches for damage, or internal shorts.
- ✓ Remove panel cover and check that all relays are firmly seated in their bases.

Carriage Malfunction

- 🔍 Visually inspect for loose wires and for signs of arcing or burning of any of the components.

☎ It is advisable to call for technical assistance at the point.

Technical and Customer Service is available from Kalamazoo Packaging Systems, Inc., Monday through Friday 7:30 A.M. to 4:00 P.M. (EST). Stock is maintained on parts to allow us to ship the same day on most orders.

If you have a problem, we want to know about it! Please call and report any difficulties you may encounter.

- **Local - (616) 534-2600**
- **National - (800) 253-4625**

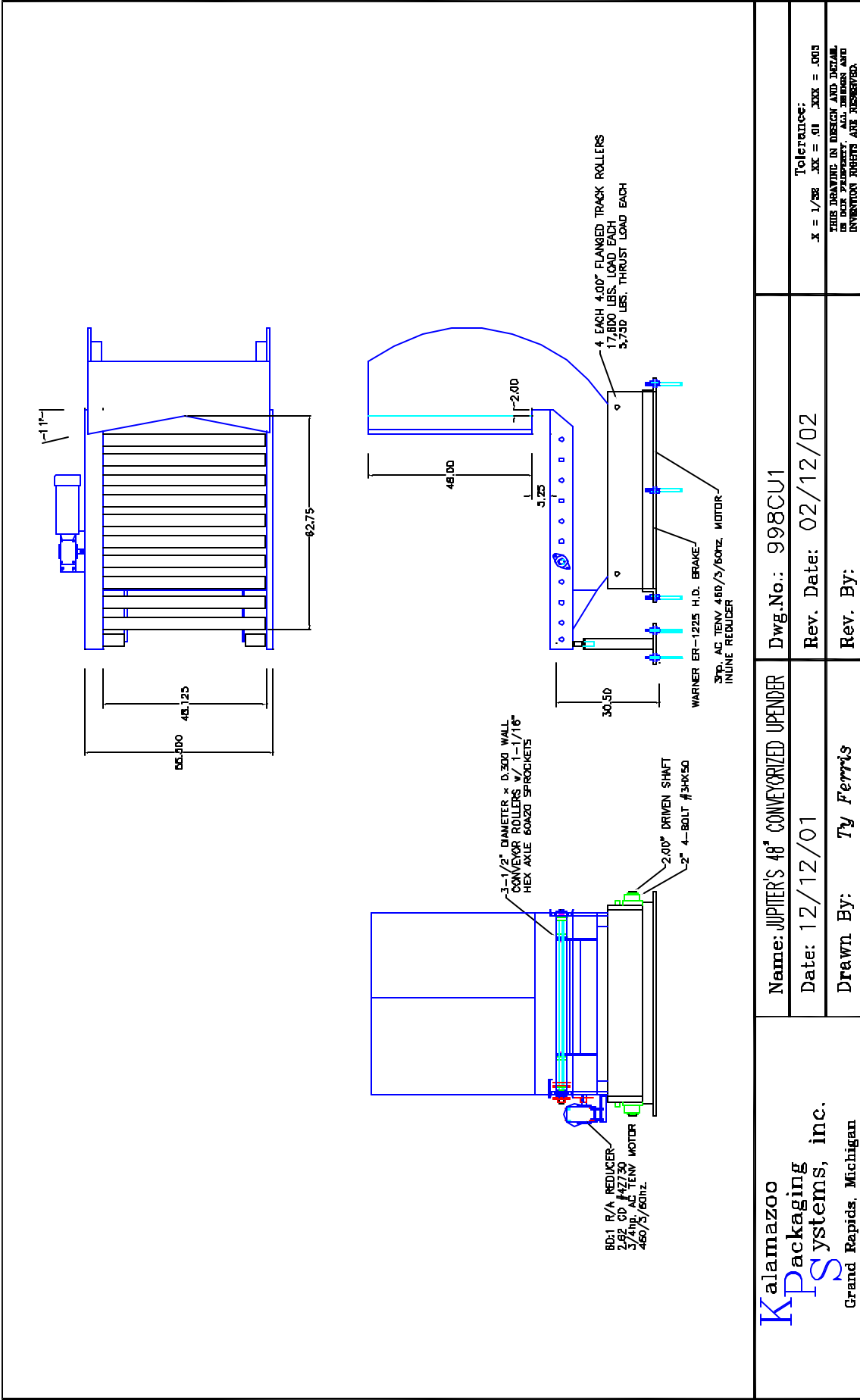

Kalamazoo
KPS packaging systems, inc.
 Grand Rapids, Michigan

Name: JUPITER'S 48" CONVEYORIZED UPENDER
 Date: 12/12/01
 Drawn By: Ty Ferris

Dwg.No.: 998CU1
 Rev. Date: 02/12/02
 Rev. By:

Tolerance:
 X = 1/32 XX = .01 XXX = .003
 THIS DRAWING IN DESIGN AND DETAIL IS OUR PROPERTY. ALL DIMENSIONS AND INVENTION RIGHTS ARE RESERVED.

PARTS LIST

CONVEYORIZED UPENDER

<u>Ref.</u>	<u>Part #</u>	<u>Description</u>	<u>Qty</u>
1	998001	1-1/2 INLINE REDUCER CBN-2504-S-B3-355-U-145CT	1
1	998002	1-1/2 hp460/3/60hz. 145TC MOTOR w/BRAKEP14G9257	1
2	998003	120B12x 2.375 DRIVE SPROCKET	1
3	998004	4" EXC. TRACK ROLLER FTRE4.00	2
4	998005	4" TRACK ROLLER FTR-4.00	2
5	998006	2" 4-BOLT FLANGE BRG. #3HX50	2
6	998007	2" UPENDER DRIVE SHAFT DWG.# 998CU-012	1
7	998008	120B12x 2 IDLER SPROCKETS	2
8	998009	120B16x 2 DRIVEN SPROCKET	1
9	998010	60B16x 1-7/16 CONV. DRIVEN SPROCKET	1
10	998011	60B18x 1-1/4 CONV. DRIVE SPROCKET	1
11	210890- 210900	QD LIMIT SWITCH w/ ADJ. LEVER ARM	2
12	998012	3/4 HP. 460/3/60hz. 56C MOTOR	1
13	998013	60:1 R/A RREDUCER 2.62CD 56C #4Z730	1
14	998014	10.375 CONV. IDLER ROLLER DWG.# 402a-CIR-10	1
15	998015	6.50 CONV. IDLER ROLLER DWG.# 402a-CIR-6	1
16	998016	UPENDER DRIVE ROLLER DWG.# 402a-DDS	1
17	998017	UPENDER DRIVEN ROLLER DWG. #402a-DS	10
18	121074	1-7/16" 2-BOLT FLANGE BRG. #4xw52	2
19	212380	MINI BEAM SENSOR #SM312	2
20	212581	REFLECTOR	2
21	998018	#120 CHAIN	2

PARTS LIST

UPENDER CONSOLE

<u>Ref.</u>	<u>Part Number</u>	<u>Description</u>	<u>Qty</u>
1	998032	UPENDER CONSOLE DECAL # W998-B2	1
2	207110	E-STOP PUSH OFF/ TURN TO RESET	1
3	207001	GREEN PUSH BUTTON	1
4	207055	RED PUSH BUTTON	1
5	207056	BLUE PUSH BUTTON	1
6	207058	YELLOW PUSH BUTTON	1
7	207057	WHITE PUSH BUTTON	1

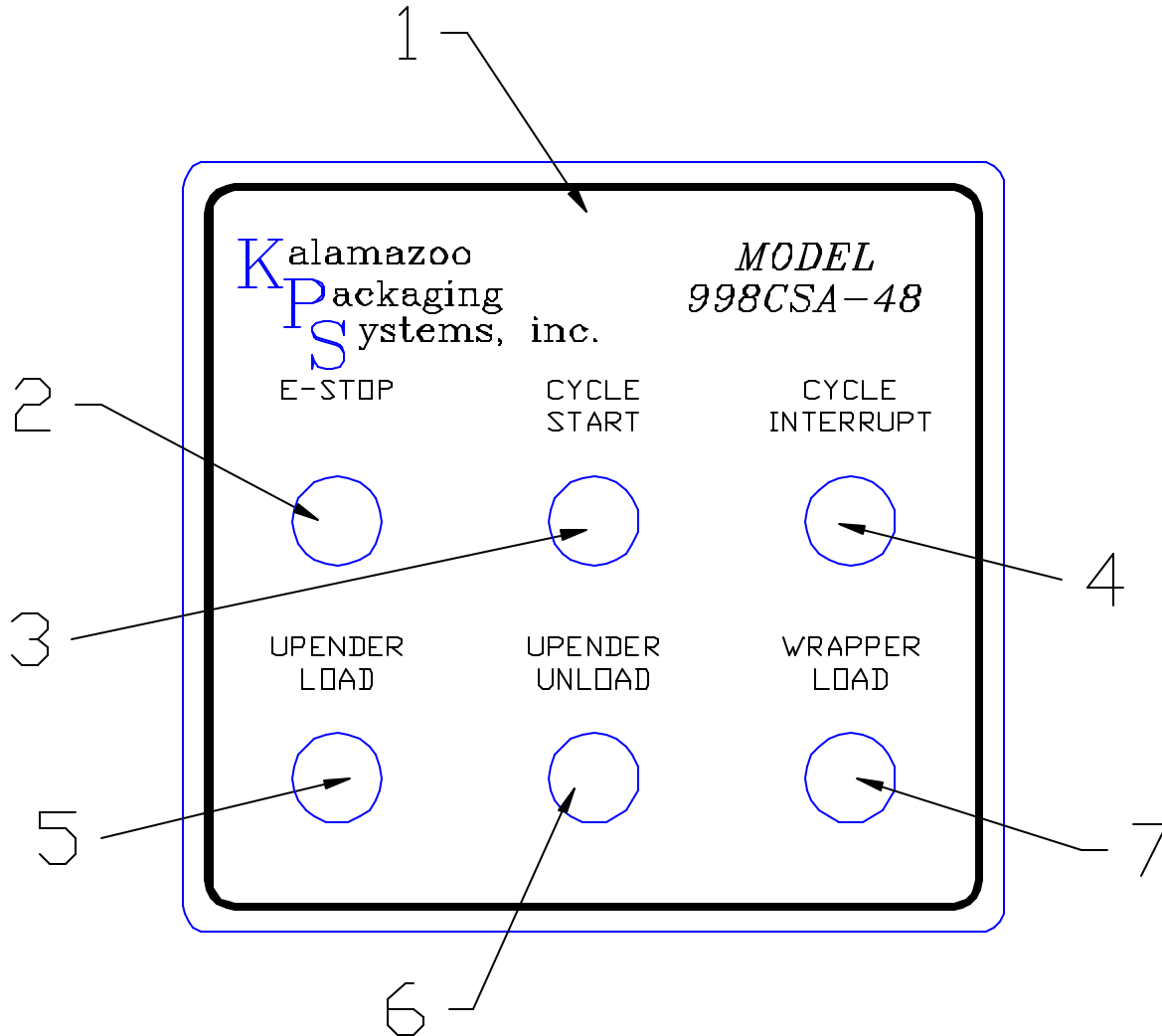

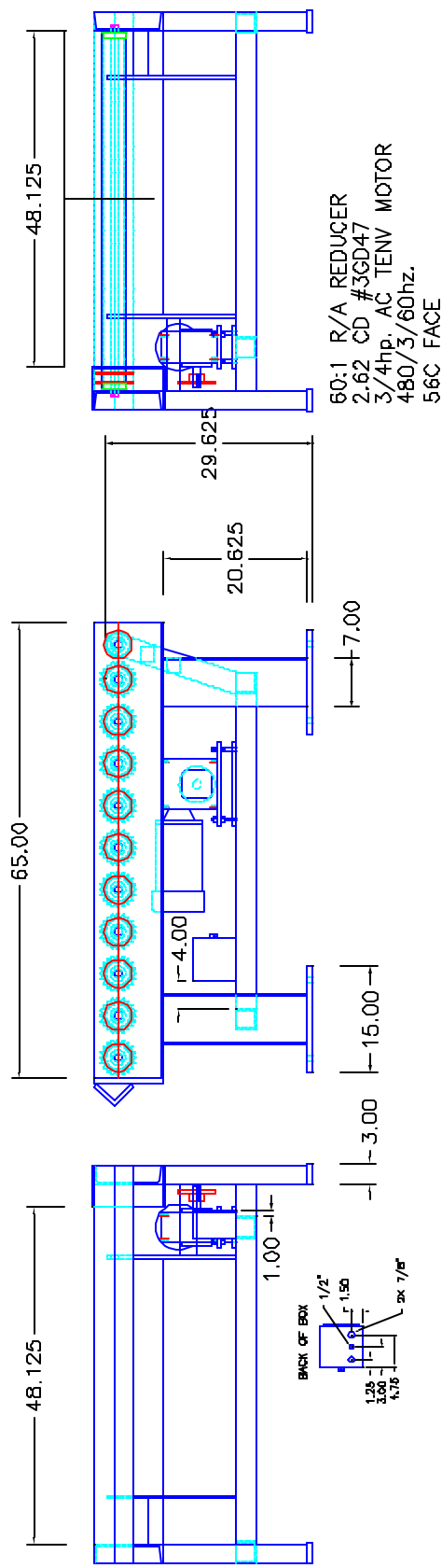
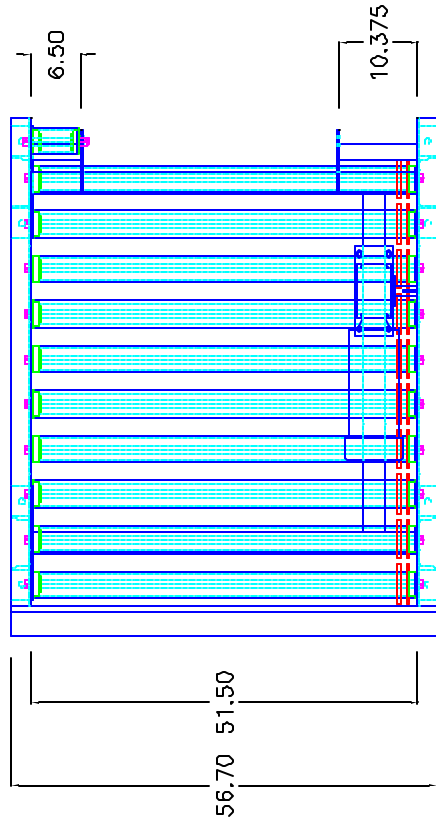

60:1 R/A REDUCER
 2.62 CD #3GD47
 3/4hp. AC TENV MOTOR
 480/3/60hz.
 56C FACE

Kalamazoo Packaging Systems, inc. Grand Rapids, Michigan	Name: JUPITER'S 48" #2 INPUT CONV.	Dwg.No.: 9981C	Tolerance: X - 1/32 XX - .01 XXX - .005
	Date: 12/12/01	Rev. Date: 02/12/02	<small>THIS DRAWING IN DESKTOP AND PRINTOUT IS OUR PROPERTY. ALL DESIGN AND INVENTION RIGHTS ARE RESERVED.</small>
	Drawn By: Ty Ferris	Rev. By:	

PARTS LIST

INPUT #2 CONVEYOR

<u>Ref.</u>	<u>Part #</u>	<u>Description</u>	<u>Qty</u>
1	998012	3/4 HP. 460/3/60hz. 56C MOTOR	1
2	998019	60:1 R/A REDUCER 2.62CD 56C #3GD47	1
3	998011	60B18x 1-1/4 CONV. DRIVE SPROCKET	1
4	998014	10.375 CONV. IDLER ROLLER DWG.# 402a-CIR-10	1
5	998015	6.50 CONV. IDLER ROLLER DWG.# 402a-CIR-6	1
6	998017	DRIVEN ROLLER DWG. #402a-DS	10
7	212380	MINI BEAM SENSOR #SM312	2
8	212581	REFLECTOR	2
9	212383	MINI BEAM SENSOR #SM312VAG (TURNTABLE A.S.)	4

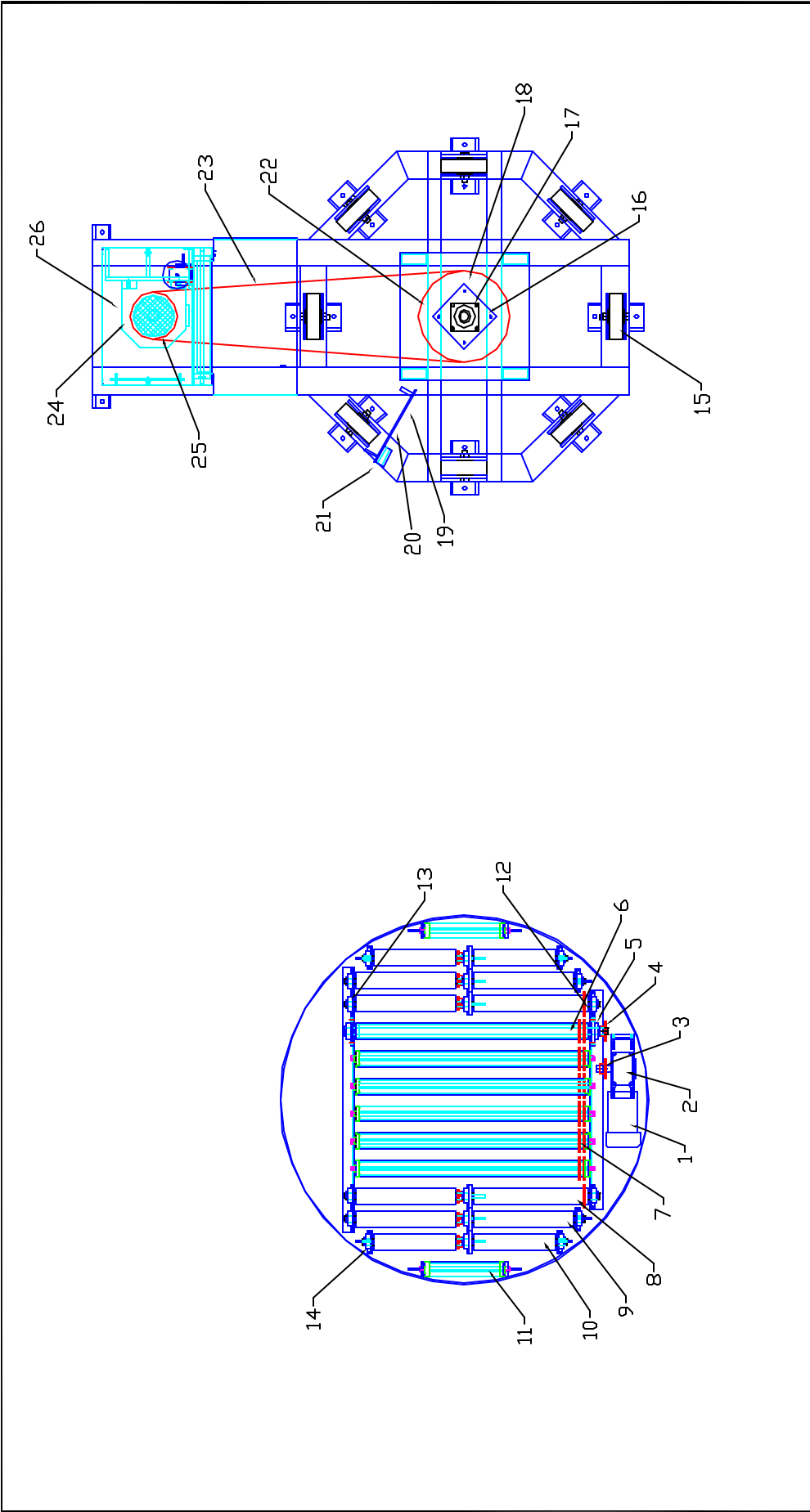

<p>Kalamazoo Packaging Systems, inc. Grand Rapids, Michigan</p>	<p>Name: JUPITER 998 TURNTABLE</p>	<p>Dwg.No.: 998TT-1</p>
	<p>Date: 12/12/01</p>	<p>Rev. Date:</p>
	<p>Drawn By: Ty Ferris</p>	<p>Rev. By:</p>
		<p>Tolerance: X = 1/32 XX = .01 XXX = .003 THIS DRAWING IN DESIGN AND DETAIL IS OUR PROPERTY. ALL RIGHTS AND INVENTION RIGHTS ARE RESERVED.</p>

PARTS LIST

998 TURNTABLE AND CONVEYOR

<u>Ref.</u>	<u>Part #</u>	<u>Description</u>	<u>Qty</u>
		DISC	
1	998012	3/4 HP. 460/3/60hz. 56C MOTOR	1
2	998019	60:1 R/A RREDUCER 2.62CD 56C #3GD47	1
3	998011	60B18x 1-1/4 CONV. DRIVE SPROCKET	1
4	998010	60B16x 1-7/16 CONV. DRIVEN SPROCKET	1
5	121074	1-7/16" 2-BOLT FLANGE BRG. #4xw52	2
6	998016	DRIVE ROLLER DWG.# 402a-DDS	1
7	998017	DRIVEN ROLLER DWG. #402a -DS	5
8	998019	POWERED TRANSITION ROLLER #1	2
9	998020	POWERED TRANSITION ROLLER #2	2
10	998021	POWERED TRANSITION ROLLER #3	2
11	998022	17.25" CONV. IDLER ROLLER #402a-CIR-17	2
12	212581	REFLECTOR	2
13	212380	MINI BEAM SENSOR #SM312	2
14	121071	1-1/4" 2-BOLT FLANGE BRG.	18
		TURNTABLE	
15	122813	10x3 PHENOLIC WHEEL w/ TAPERED ROLLER BRG.	8
16	998TT-019	CENTER SHAFT	1
17	998023	2" 4-BOLT FLANGE BRG. #MBF-2	2
18	998024	SLIP RING #S150N8KP1	1
19	210890-210900	QD LIMIT SWITCH w/ ADJ. LEVER ARM	1
20	998025	1-1/2" BORE 6" CYLINDER #FDR-24-2	1
21	998026	LOCKING PIN DWG.# 998TT-001b1	1
22	998027	DRIVEN SPROCKET #120C40x 2"	1
23	#120	#120 CHAIN	1
24	998028	3HP. GEARBOX INLINE # CBN-2503-S-V5-112-U-182TC-3	1
25	998029	3HP. 460/3/60hz. 1800 RPM 182TC MOTOR	1
26	998030	DRIVE SPROCKET # H120R20	1
27	998031	DRIVE SPROCKET BUSHING # TYPE 5 x 2.375	1

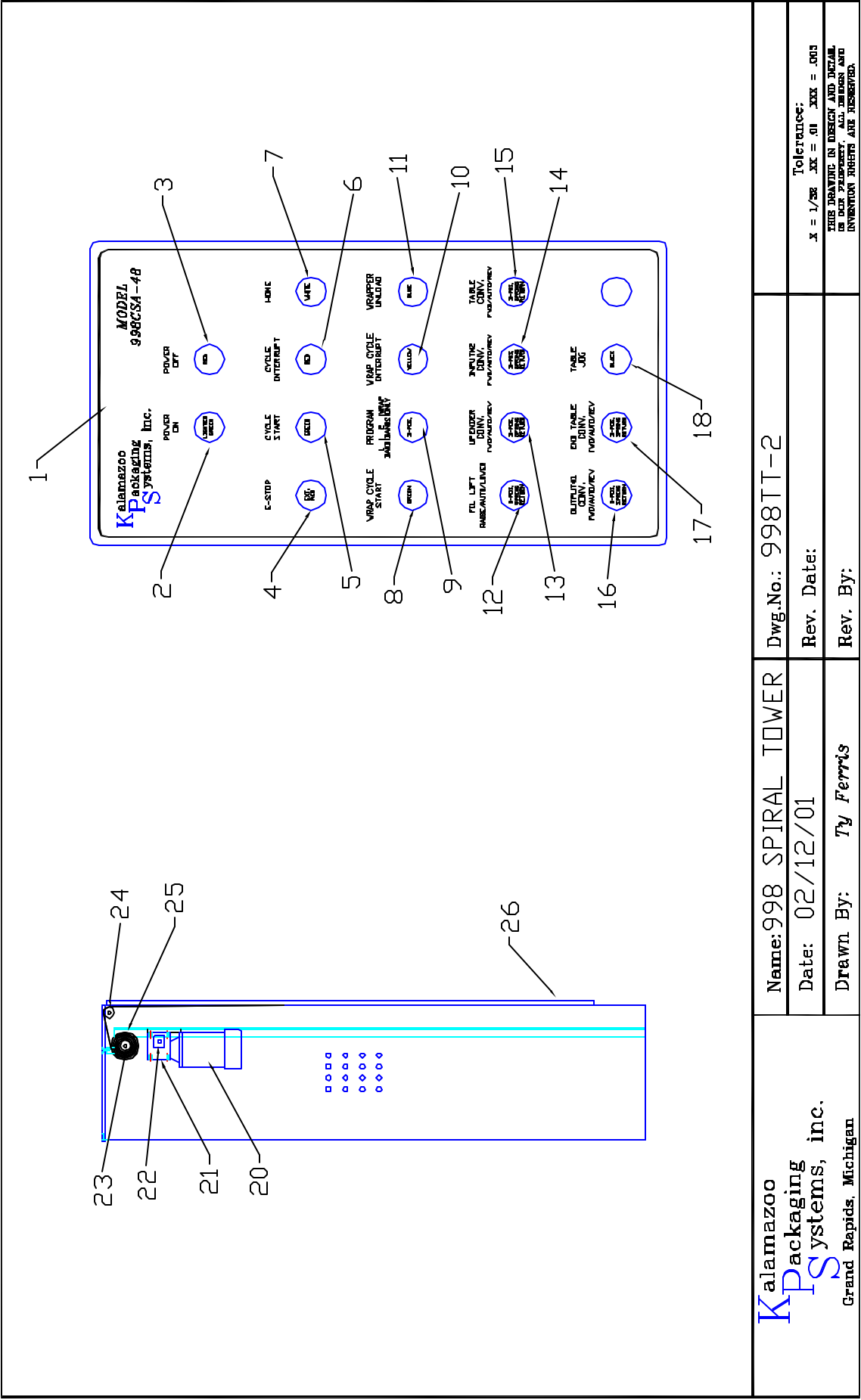

Kalamazoo Packaging Systems, inc. Grand Rapids, Michigan	Name: 998 SPIRAL TOWER	Dwg.No.: 998TT-2
	Date: 02/12/01	Rev. Date:
	Drawn By: Ty Ferris	Rev. By:
		Tolerances: X = 1/32 XX = .01 XXX = .003 THIS DRAWING IN DESIGN AND INITIAL IS OUR PROPERTY. ALL DIMENSIONS AND DIMENSION TOLERANCES ARE RESERVED.

PARTS LIST

998 SPIRAL TOWER

<u>Ref.</u>	<u>Part #</u>	<u>Description</u>	<u>Qty</u>
1	998032	MODEL 998CSA-48 CONTROL PANEL DECAL # W998-B1	1
2	207070	LIGHTED GREEN PUSH BUTTON	1
3	207050	RED MUSHROOM PUSH BUTTON	1
4	207110	E-STOP PUSH OFF/ TURN TO RESET	1
5	207001	GREEN PUSH BUTTON	1
6	207055	RED PUSH BUTTON	1
7	207057	WHITE PUSH BUTTON	1
8	207001	GREEN PUSH BUTTON	1
9	207103	3-POS SELCETOR	1
10	207058	YELLOW PUSH BUTTON	1
11	207056	BLUE PUSH BUTTON	1
12	207107	3-POS SELECTOR SPRING RETURN	1
13	207107	3-POS SELECTOR SPRING RETURN	1
14	207107	3-POS SELECTOR SPRING RETURN	1
15	207107	3-POS SELECTOR SPRING RETURN	1
16	207107	3-POS SELECTOR SPRING RETURN	1
17	207107	3-POS SELECTOR SPRING RETURN	1
18	207060	BLACK PUSH BUTTON	1
20	998033	1/2HP. 40/3/60hz. 1800RPM 56C MOTOR #P56x1338	1
21	106100	60:1 R/A REDUCER #4Z284	1
22	107977	40B17x 5/8 DRIVE SPROCKET	1
23	998034	BELT DRIVE ROLLER DWG.# 998TT-023	1
24	998035	BELT IDLER ROLLER DWG.# 998TT-022	1
25	998036	FILM LIFT BELT	1
26	998037	FILM LIFT SENSOR BRACKET	2

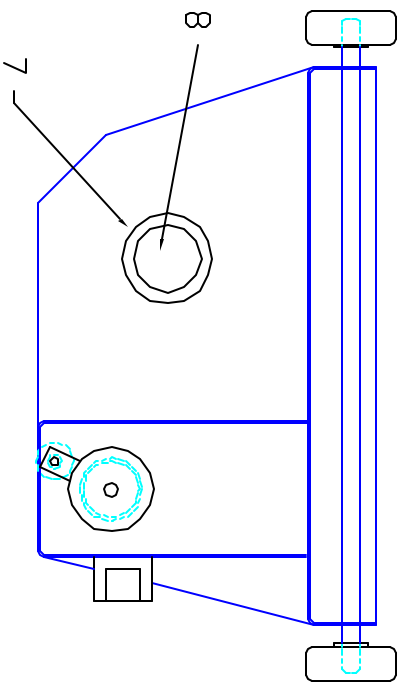
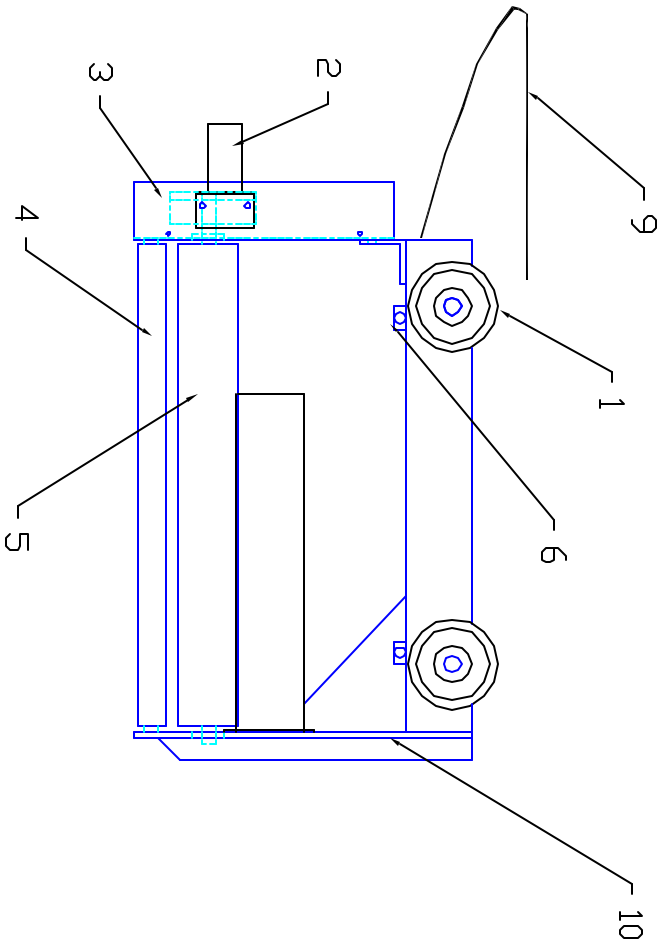

Kalamazoo
Packaging
Systems, inc.
 Grand Rapids, Michigan

Name: 988 20" VARIABLE TENSION FILM DELIVERY
 Date: 02/12/01
 Drawn By: Ty Ferris

Dwg. No.: 998TT-3
 Rev. Date:
 Rev. By:

Tolerance:
 X - 1/32 XX - .01 XXX - .003
 THIS DRAWING IS UNDER PATENT AND SHALL
 BE OUR PROPERTY. ALL DESIGN AND
 INVENTION RIGHTS ARE RESERVED.

PARTS LIST

998 20" VARIABLE TENSION FILM DELIVERY

<u>Ref.</u>	<u>Part #</u>	<u>Description</u>	<u>Qty</u>
1	122250	4x1-1/2x 3/4" WHEEL	4
2	213000	BANNER PHOTO EYE CHANGED TO A #SU925QD-24	1
3	130500	3-3/4" WARNER BRAKE # EB-375	1
4	537125	1-1/4" PVC x 21"	1
4	120600	5/8"x 1-3/8" FLANGED BRG.	2
4	561000	5/8" G&P SHAFT x 21" TAPED BOTH END 3/8-16	1
5	349001	20" BRAKE ROLLER w/COVER	1
5	120650	5/8"x 1-3/8" PER. FLANGED BRG.	2
6	212380	MINI BEAM SENSOR # SM312LVAG	2
7	120860	3" THRUST WASHER	1
8	349100	20" FILM CORE	1
9	210056	16/12 FLAT CORD	1
11	998038	20" FILM CARRAGE DWG.#998TT-017	1

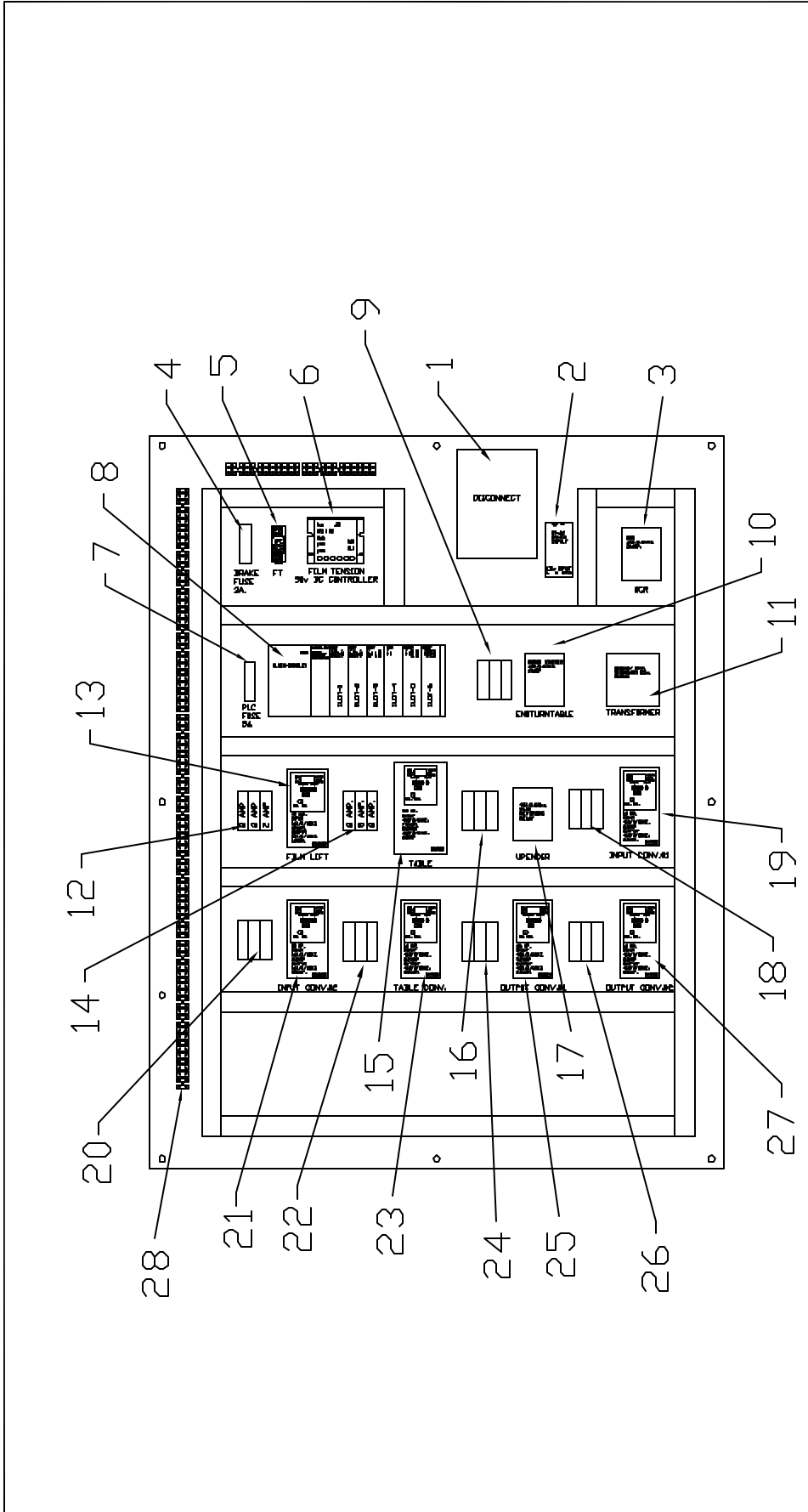

Kalamazoo KPS ackaging systems, inc. Grand Rapids, Michigan	Name: 998 SUB PANEL LAYOUT Dwg.No.: 998-SUB-1	
	Date: 02/12/01 Rev. Date:	
Drawn By: <i>Ty Ferris</i> Rev. By:		Tolerance: X - 1/32 XX - .01 XXX - .003 THIS DRAWING IN DETAIL AND DETAIL IS OUR PROPERTY. ALL DESIGN AND INVENTION RIGHTS ARE RESERVED.

PARTS LIST

998 SUB PANEL

<u>Ref.</u>	<u>Part #</u>	<u>Description</u>	<u>Qty</u>
1	998039	30 amp. FUSED DISCONNCT	1
2	998030	24v DC POWER SUPPLY	1
3	998031	40 amp. 24v DC COIL (MCR)	1
4	210771	1 POLE FUSE HOLDER	1
4	210777	3 amp. FUSE (FILM BRAKE)	1
5	208250	2PDT 10a. RELAY	1
5	208260	8-PIN BASE	1
6	131200	90/180 VOLT DC CONTROLLER (FILM BRALE)	1
7	210771	1 POLE FUSE HOLDER	1
7	210777	3 amp. FUSE (PLC)	1
8	998032	ALLEN-BRADY PLC 5/01	1
9	210773	3 POLE FUSE HOLDER	1
9	210778	5 amp. FUSE (ENDTABLE)	3
10	998033	5 amp. 24v DC COIL RELAY (ENDTABLE)	1
11	209102	150va TRANSFORMER # 4R884	1
12	210773	3 POLE FUSE HOLDER	1
12	210820	2 amp. FUSE (FILM LIFT)	3
13	998034	1/2HP. 460/3/60hz AC INVERTER (FILM LIFT)	1
14	210773	3 POLE FUSE HOLDER	1
14	210781	8 amp. FUSE (TURNTABLE)	3
15	998035	3hp. 460/3/60hz AC INVERTER (TURNTABLE)	1
16	210773	3 POLE FUSE HOLDER	1
16	210778	5 amp. FUSE (UPENDER)	3
17	998036	5 amp. REVERSING RELAY (UPENDER)	1
18	210773	3 POLE FUSE HOLDER	1
18	210777	3 amp. FUSE (INPUT CONV.#1)	3
19	998037	1HP 460/3/60hz. AC INVERTER (INPUT CONV.#1)	1
20	210773	3 POLE FUSE HOLDER	1
20	210777	3 amp. FUSE (INPUT CONV.#2)	3
21	998037	1HP 460/3/60hz. AC INVERTER (INPUT CONV.#2)	1
22	210773	3 POLE FUSE HOLDER	1
22	210777	3 amp. FUSE (TABLE CONV)	3
23	998037	1HP 460/3/60hz. AC INVERTER (TABLE CONV.)	1

PARTS LIST

998 SUB PANEL

<u>Ref.</u>	<u>Part #</u>	<u>Description</u>	<u>Qty</u>
24	210773	3 POLE FUSE HOLDER	1
24	210777	3 amp. FUSE (OUTPUT CONV. #1)	3
25	998037	1HP 460/3/60hz. AC INVERTER (OUTPUT CONV.#1)	1
26	210773	3 POLE FUSE HOLDER	1
26	210777	3 amp. FUSE (OUTPUT CONV. #2)	3
27	998037	1HP 460/3/60hz. AC INVERTER (OUTPUT CONV.#2)	1
28	209700	12 TERMINAL STRIP	10

Kalamazoo
Packaging
Systems, Inc.
 Grand Rapids, Michigan

Name: JUPITER'S 48" OUTPUT CONV.
 Date: 12/12/01
 Drawn By: *Ty Ferris*

Dwg.No.: 9980c-1
 Rev. Date: 02/12/02
 Rev. By:

Tolerance:
 .x = .1/32 .xx = .01 .xxx = .003
 THIS DRAWING IN DESIGN AND DETAIL
 IS OUR PROPERTY. ALL DESIGN AND
 INVENTION RIGHTS ARE RESERVED.

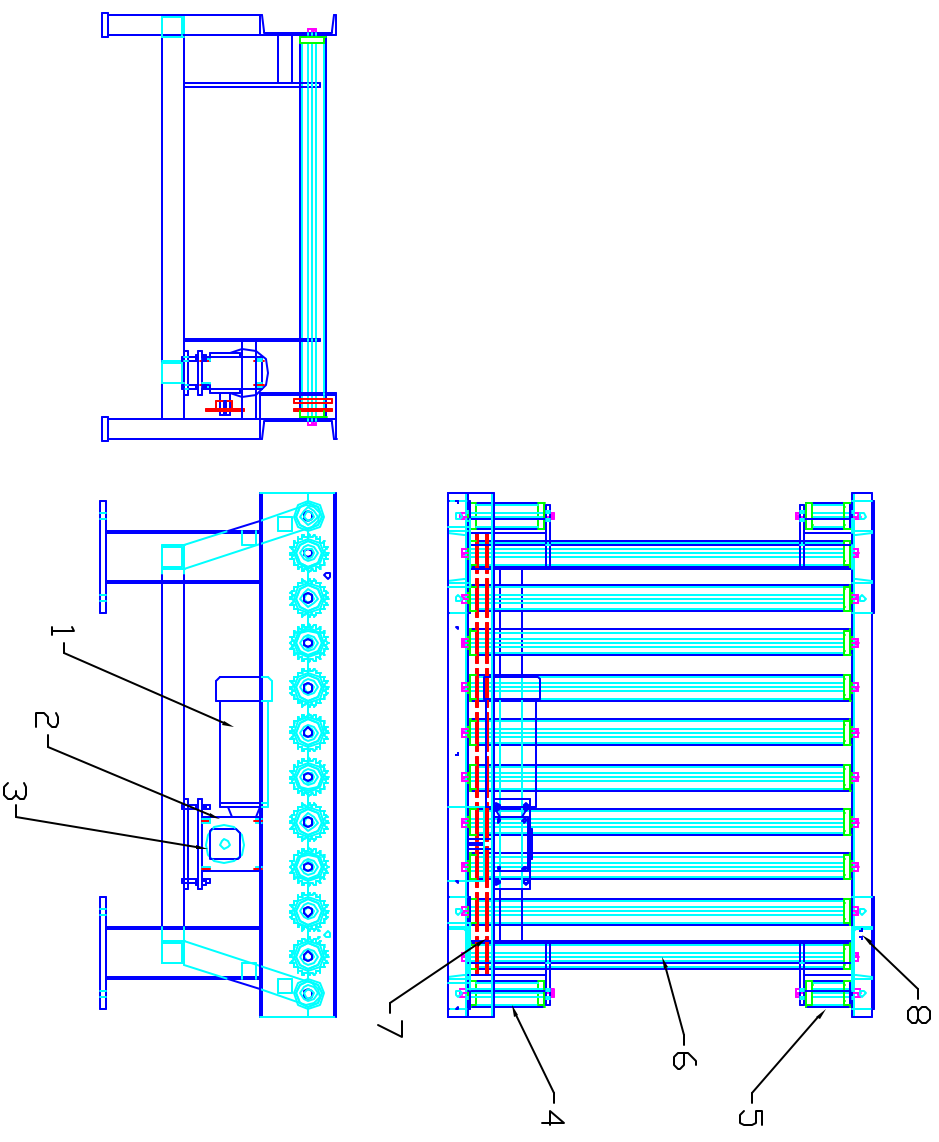

PARTS LIST

OUTPUT CONVEYOR

<u>Ref.</u>	<u>Part #</u>	<u>Description</u>	<u>Qty</u>
1	998012	3/4 HP. 460/3/60hz. 56C MOTOR	1
2	998019	60:1 R/A REDUCER 2.62CD 56C #3GD47	1
3	998011	60B18x 1-1/4 CONV. DRIVE SPROCKET	1
4	998014	10.375 CONV. IDLER ROLLER DWG.# 402a-CIR-10	2
5	998015	6.50 CONV. IDLER ROLLER DWG.# 402a-CIR-6	2
6	998017	DRIVEN ROLLER DWG. #402a-DS	10
7	212380	MINI BEAM SENSOR #SM312	1
8	212581	REFLECTOR	1
9	212383	MINI BEAM SENSOR #SM312VAG (END TABLE A.S.)	2
10	998038	HYD. PUMP UNIT # W20-3T-G3N-VSM1SR-HEA41R	1

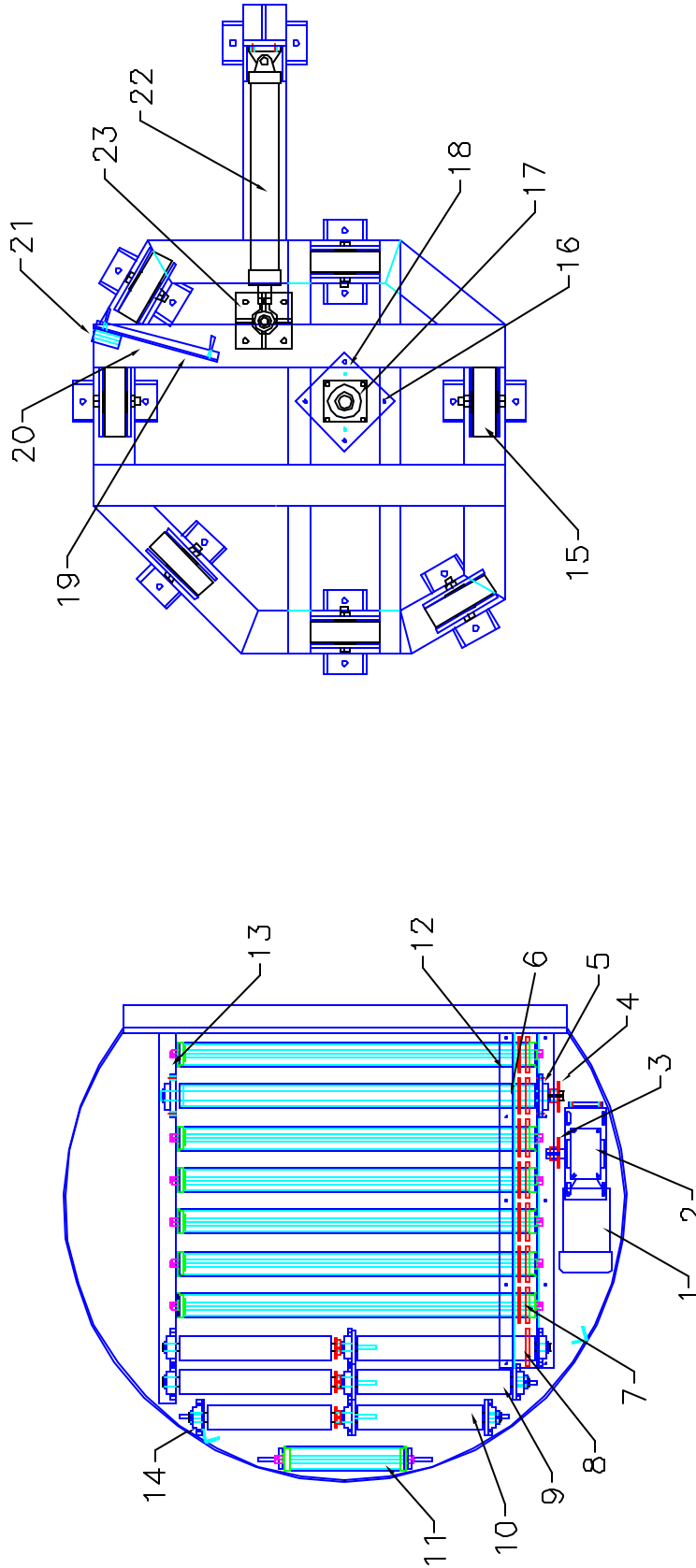

Kalamazoo
Packaging
Systems, inc.
 Grand Rapids, Michigan

Name: 90 DEG. END TURNTABLE Dwg.No.: 998EIT-1

Date: 04/29/02

Rev. Date:

Drawn By: Ty Ferris

Rev. By:

Tolerance:

$x = 1/32$ $xx = .01$ $xxx = .005$
 THIS DRAWING IS DESIGN AND INTEL.
 OR COPY PROPRIETARY. ALL DIMENSIONS AND
 INVENTION RIGHTS ARE RESERVED.

PARTS LIST

90 DEG. END TURNTABLE AND CONVEYOR

<u>Ref.</u>	<u>Part #</u>	<u>Description</u>	<u>Qty</u>
		DISC	
1	998012	3/4 HP. 460/3/60hz. 56C MOTOR	1
2	998019	60:1 R/A RREDUCER 2.62CD 56C #3GD47	1
3	998011	60B18x 1-1/4 CONV. DRIVE SPROCKET	1
4	998010	60B16x 1-7/16 CONV. DRIVEN SPROCKET	1
5	121074	1-7/16" 2-BOLT FLANGE BRG. #4xw52	2
6	998016	DRIVE ROLLER DWG.# 402a-DDS	1
7	998017	DRIVEN ROLLER DWG. #402a-DS	6
8	998019	POWERED TRANSITION ROLLER #1	1
9	998020	POWERED TRANSITION ROLLER #2	1
10	998021	POWERED TRANSITION ROLLER #3	1
11	998022	17.25" CONV. IDLER ROLLER #402a-CIR-17	1
12	212581	REFLECTOR	1
13	212380	MINI BEAM SENSOR #SM312	1
14	121071	1-1/4" 2-BOLT FLANGE BRG.	9
		TURNTABLE	
15	122813	10x3 PHENOLIC WHEEL w/ TAPERED ROLLER BRG.	7
16	998TT-019	CENTER SHAFT	1
17	998023	2" 4-BOLT FLANGE BRG. #MBF-2	1
18	998024	SLIP RING #S150N8KP1	1
19	210890-210900	QD LIMIT SWITCH w/ ADJ. LEVER ARM	1
20	998025	1-1/2" BORE 6" CYLINDER #FDR-24-2	1
21	998026	LOCKING PIN DWG.# 998TT-001b1	1
22	998027	7X23 HYD. CYLINDER #1531-61-54-S-7x23	1
23	998028	TURNING POST DWG.# 998ETT-012c	1

PARTS LIST

END TABLE CONSOLE

<u>Ref.</u>	<u>Part #</u>	<u>Description</u>	<u>Qty</u>
1	998032	END TABLE CONSOLE DECAL # W998-B3	1
2	207110	E-STOP PUSH OFF/ TURN TO RESET	1
3	207001	GREEN PUSH BUTTON	1
4	207055	RED PUSH BUTTON	1
5	207056	BLUE PUSH BUTTON	1
6	207058	YELLOW PUSH BUTTON	1

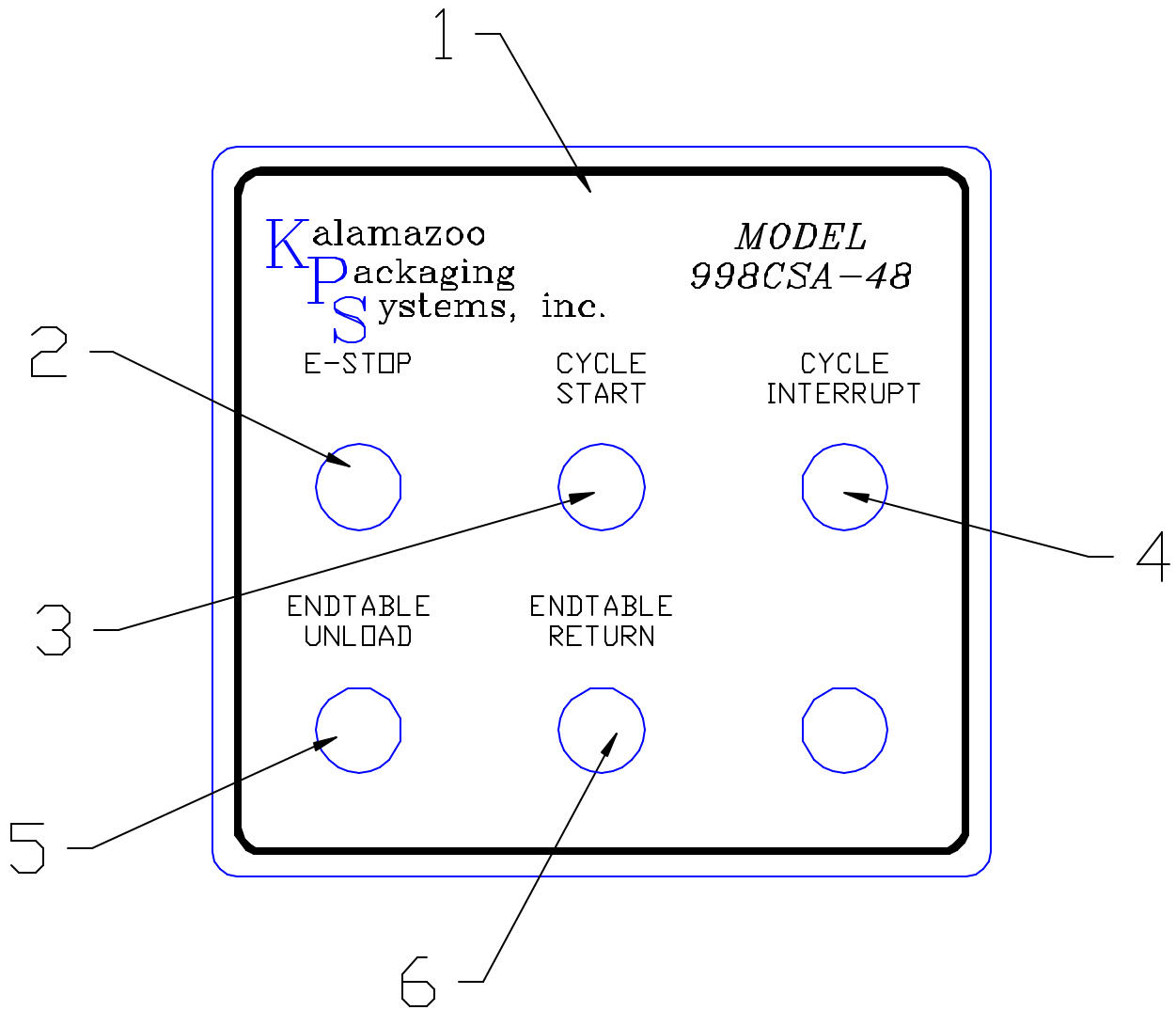

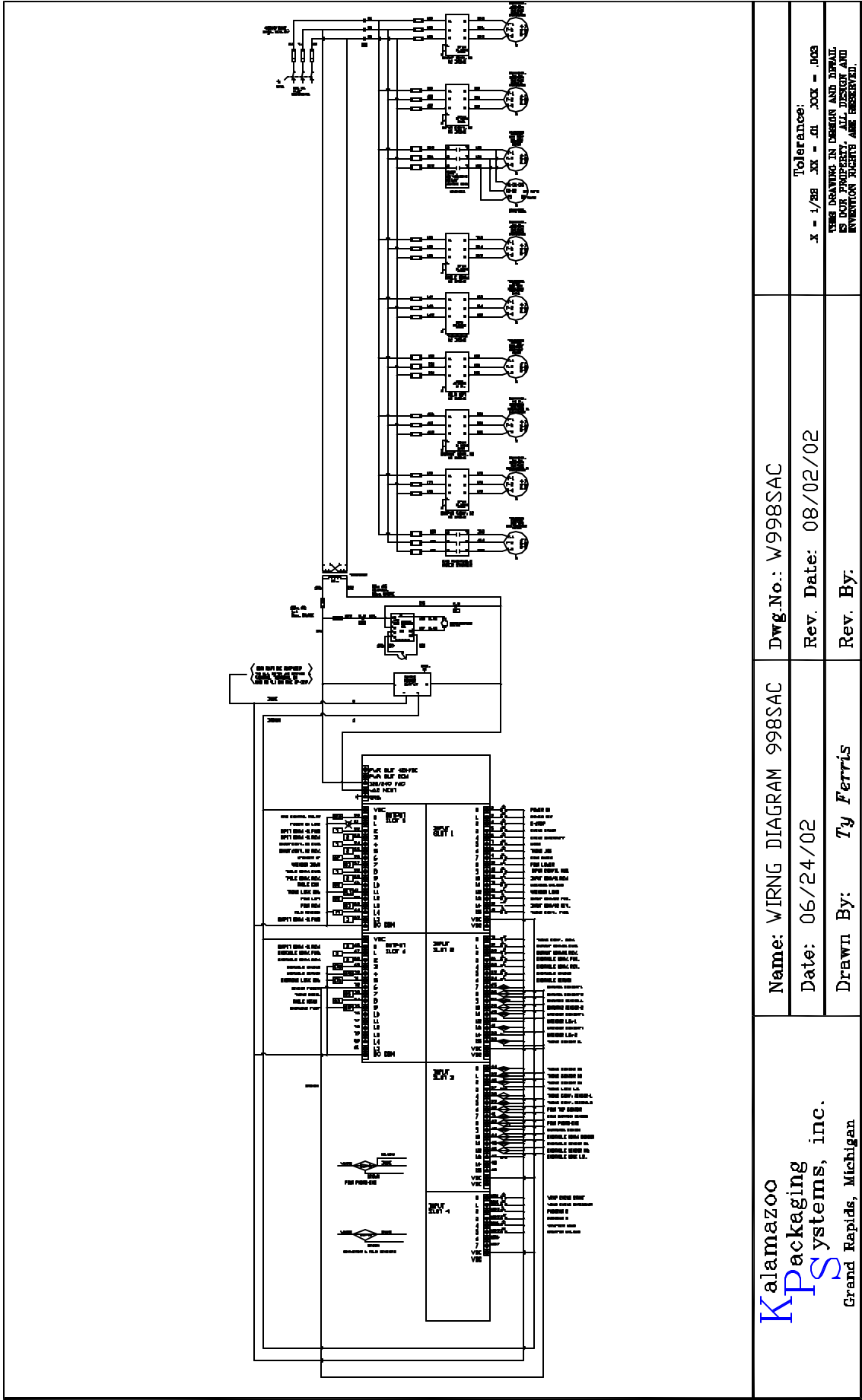

Kalamazoo
PS Packaging systems, inc.
 Grand Rapids, Michigan

Name: WIRNG DIAGRAM 998SAC

Dwg.No.: W998SAC

Date: 06/24/02

Rev. Date: 08/02/02

Drawn By: Ty Ferris

Rev. By:

Tolerance:

x - 1/88 XX - 21 XXX - 1003

THIS DRAWING IS DESIGN AND DRAWN BY OUR PROPERTY. ALL DESIGN AND INVENTION RIGHTS ARE RESERVED.

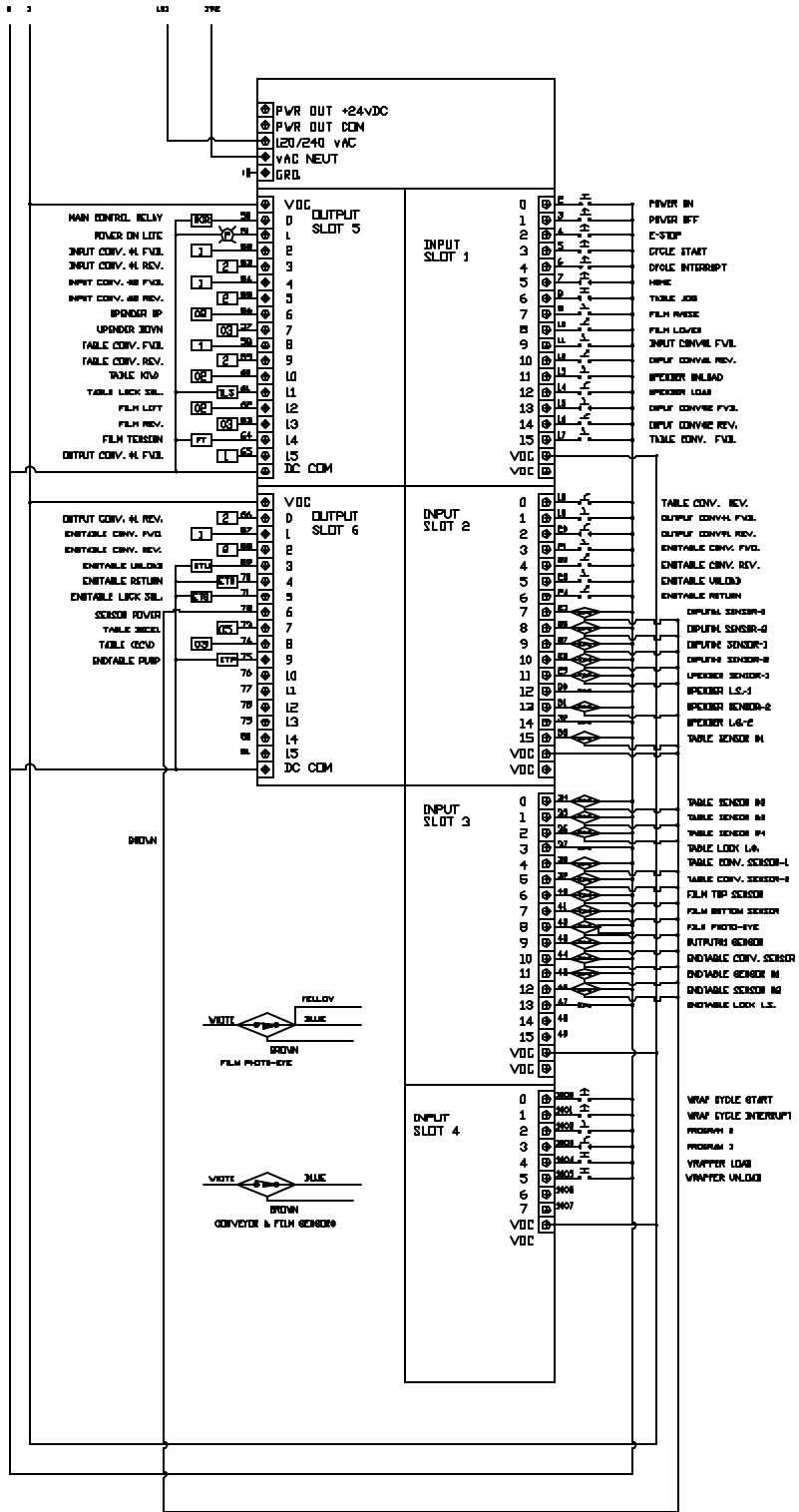

<p>Kalamazoo Packaging Systems, inc. Grand Rapids, Michigan</p>	<p>Name: WIRING DIA. 998SAC</p>	<p>Dwg.No.: W998SAC2</p>	<p>Tolerance: X = 1/32 XX = .01 XXX = .003</p>
	<p>Date: 06/24/02</p>	<p>Rev. Date: 08/02/02</p>	<p>THIS DRAWING IN DESIGN AND INCHARGE OF OUR PERFORMANCE. ALL DIMENSIONS AND DIMENSIONAL TOLERANCES ARE RESERVED.</p>
	<p>Drawn By: Ty Ferris</p>	<p>Rev. By:</p>	

FILM LIFT

SP-120	MD60
A01-00	P038-0
A02-01	P036-2
A03-60	P032-60
A04-60	P035-60
A11-60	P034-60
A92-2.0	A067-2.0
A93-0.2	A068-0.2
B83-10	A091-10
C01-00	
C02-01	
C03-09	A52-1

TURNTABLE

SP-120	MD60
A01-00	P038-0
A02-01	P036-2
A03-60	P032-60
A04-60	P035-60
A11-60	P034-60
A92-6.0	A067-6.0
A93-3.0	A068-3.0
B83-10	A091-10
C01-00	
C02-01	
C03-09	A52-1