



## **SERIES 862FA-D12**

### **FULLY-AUTOMATIC WINDER STRETCH WRAP SYSTEM WITH CONVEYORS**



# OPERATOR MANUAL

Book 1 of 2

## Table of Contents

Warranty .....	3
Assembly .....	4
Loading Film .....	5
Operating Controls:	
Main Control Cabinet.....	6
Zone 1 .....	6
Zone 2 .....	7
Zone 3 .....	7
Zone 4 .....	7
Operating Instructions .....	8
Maintenance .....	9
Adjustments .....	9
Trouble Shooting .....	10
AC Drive Programming .....	11
System Layout .....	12-13
Parts List:	
Zone 1 Remote Console .....	14-15
Swing Out Conveyor .....	16-19
Zone 1 Pop-Up Conveyor .....	20-22
Band Roller Conveyor .....	23-28
Zone 3 Remote Console .....	29-30
Zone 2 Pop-Up Conveyor .....	31-33
Zone 2 Remote Console .....	34-35
Input Belt Conveyor .....	36-42
Air System Valve Bank .....	43-44
Horizontal Winder Base .....	45-48
Horizontal Winder Ring.....	49-51
Automatic Film Holder and Cutter .....	52
Air Powered Hold Down Rollers.....	53-54
Main Control Console .....	55-56
Control Cabinet Sub Panel .....	57-59
Control Cabinet .....	60-65
Output Belt Conveyor .....	66-68
Zone 4 Remote Console .....	69-70
Output Gravity Roller Conveyors.....	71
Wiring Diagram .....	72-78
PLC Program .....	79-183

## **Introduction**

Congratulations! Your purchase of a Kalamazoo Series 800 Horizontal Winder Stretch Wrap System will provide you with years of efficient stretch wrapping service. Your investment will ensure that your products will arrive cleaner, with less damage and pilferage at their destination at a lower cost to you.

## **Warranty**

Kalamazoo Packaging Systems products carry a LIMITED LIFETIME WARRANTY on all K.P.S. manufactured components; all parts not manufactured by Kalamazoo Packaging Systems will be subject to the original manufacturer's warranty.

Kalamazoo Packaging systems, Inc. (KPS) agrees to furnish the purchaser, without charge, F.O.B. the factory, any part found to be defective in either material or workmanship within one (1) year from date of shipment, provided the purchaser gives immediate notice of any defect and description of that defect to KPS. KPS reserves the right to inspect any defective part to verify the defect and to determine probable cause of same.

The liability of KPS under this warranty is limited to furnishing replacements for defective parts, and unless otherwise agreed to in writing, the purchaser shall bear the expense of installation.

Failure of equipment or parts due to abuse, misuse, neglect, incorrect operating techniques or power line drops or surges shall not constitute failure because of defective material or workmanship, and are expressly excluded from this warranty.

The above is the only warranty with no other guarantees which extend beyond the above and the seller disclaims any implications including but not limited to a warranty of merchantability.

## Assembly

Your Horizontal Winder has been assembled and tested at our manufacturing plant and released for shipment by a qualified technician. If the unit was shipped via common carrier or by our truck it may not be crated. **Any damage done in transit should be reported to the carrier immediately.** All our shipments are sent F.O.B. Grand Rapids, Michigan, therefore; the customer is responsible to settle any damage claims with the transportation company. Kalamazoo Packaging Systems will do everything possible to assist you in these matters.

Place the Winder in it's location.

Move the 862PB84 Input Conveyor into place and install the locking pins.

(the 862PB84 Input Conveyor has the film holder attached to the conveyor and is installed on the same side as the film door on the winder.)

Plug in the 862PB84 Input Conveyor into the control cabinet.

Move the Band Roller Conveyor into place and bolt it to the 862PB84 Input Conveyor .

Plug in the Band Roller Conveyor into the 862PB84 Input Conveyor.

Move the Zone 1 Band Belt Conveyor Base Frame into place and bolt it to the Band Roller Conveyor. Lower the Zone 1 Band Belt Conveyor Top Frame onto the Base Frame. Install the Pop-up cylinder nuts.

Plug in the Zone 1 Band Belt Conveyor into the Band Roller Conveyor.

Install the 830PB60 Swing Away Conveyor in front of the Zone 1 Band Belt Conveyor.

Install the Zone 2 Band Belt Conveyor the same as the Zone 1 Band Belt Conveyor on the other side of the Band Roller Conveyor.

Plug in the air supply.

Move the 864PB60 Output Conveyor into place and install the locking pins.

(the OUTPUT conveyor is installed on the opposite side as the film door on the winder)

Plug in the 862PB60 output conveyor into the control cabinet.

Move the Gravity Roller Conveyors to the end of the 862PB60 Output Conveyor.

Plug in the Winder into the control cabinet.

Wire in the main power drop cord 480/3/60hz. 50 AMP. into the control cabinet.

(see wiring diagram. )

Air Source required 80 P.S.I.

The System is now ready for operation.

## Film Loading

Your wrapper is equipped with a Kalamazoo Variable Tension Film Delivery System. Place a roll of 10-12" stretch film on the film core holder and thread the film as shown on the diagram below. Once the film is loaded and the desire film tension is arrived at the film tension need not be adjusted again until the brand of film or the film thickness is changed.

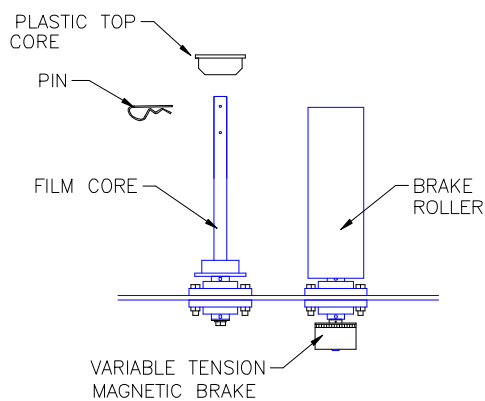
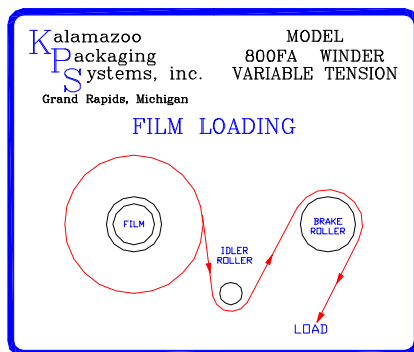

## Film Loading and Tensioning

Place a roll of 12" film onto the film holder so the film unwinds clockwise, than slide the plastic top core into place and install the pin into the hole.

(note: The film core does not change the film tension.)

**Thread the film as shown on the diagram.**

Adjust the variable tension magnetic brake to the film tension you desire. Loosen the two set screws in the brake with a 5/64" allen wrench adjust the tension and retighten the set screws.

## Operating Controls

### Main Control Cabinet

- 1 POWER ON: Green lighted push button; turns on the machine power and lights up the button.
- 2 POWER OFF: Red push button; turns off the machine power.
- 3 EMERGENCY STOP: Red (push off/ turn to reset); turns off all motors, air cylinders and hot wire.
- 4 MAIN CYCLE ENABLE: Green push button; enables the wrap cycle.
- 5 MAIN CYCLE STOP: Red mushroom push button; stops the wrap cycle.
- 6 LOAD FILM: Blue push button; opens the film cutter air cylinder, Load the film.  
After loading the film push LOAD FILM again and the film cylinder will close.
- 7 MAIN RESET: White push button; Reset the machine. Moves the winder ring to home, Closes the film cutter, and moves the hold downs up.
- 8 WINDER RING Auto/Manual: 2-position selector switch; Manually runs the Winder ring. Disengaged in the wrap cycle program.
- 9 SWING OUT CONV. Fwd/Auto/Rev: 3-position selector switch; Manually runs the Swing Out Conveyor. Disengaged in the wrap cycle program.
- 10 ZONE 1 POP-UP CONV. Fwd/Auto/Rev: 3-position selector switch; Manually runs the Zone 1 Conveyor. Disengaged in the wrap cycle program.
- 11 ZONE 1 POP-UP CONV. Auto/Raise: 2-position selector switch; Manually raises Zone 1 Conveyor. Disengaged in the wrap cycle program.
- 12 ROLLER CONV. Fwd/Auto/Rev: 3-position selector switch; Manually runs the Roller Conveyor. Disengaged in the wrap cycle program.
- 13 ZONE 2 POP-UP CONV. Fwd/Auto/Rev: 3-position selector switch; Manually runs the Zone 2 Conveyor. Disengaged in the wrap cycle program.
- 14 ZONE 2 POP-UP CONV. Auto/Raise: 2-position selector switch; Manually raises Zone 2 Conveyor. Disengaged in the wrap cycle program.
- 15 INPUT BELT CONV. Fwd./Auto/Rev.: 3-position selector switch; Manually runs the Input Belt Conveyor. Disengaged in the wrap cycle program.
- 16 INPUT HOLD DOWN Auto/Lower: 2-position selector switch: Manually lowers the input product hold downs
- 17 OUTPUT BELT CONV. Fwd./Auto/Rev.: 3-position selector switch; Manually runs the Output Belt Conveyor. Disengaged in the wrap cycle program.
- 18 OUTPUT HOLD DOWN Auto/Lower: 2-position selector switch: Manually lowers the input

### Zone 1 Remote Console

- 1 EMERGENCY STOP: Red (push off/ turn to reset); turns off all motors, air cylinders and hot wire.
- 2 ZONE 1 CYCLE ENABLE: Green push button; enables Zone 1.
- 3 ZONE 1 CYCLE STOP: Red mushroom push button; stops Zone 1.
- 4 ZONE 1 BYPASS: Black push button: Push to bypass the Stretch wrapper.
- 5 ZONE 1 RESET: White push button; reset Zone 1.
- 6 SWING OUT CONV. Fwd/Auto/Rev: 3-position selector switch; Manually runs the Swing Out Conveyor. Disengaged in the wrap cycle program.
- 7 ZONE 1 POP-UP CONV. Fwd/Auto/Rev: 3-position selector switch; Manually runs the Zone 1 Conveyor. Disengaged in the wrap cycle program.
- 8 ZONE 1 POP-UP CONV. Auto/Raise: 2-position selector switch; Manually raises Zone 1 Conveyor. Disengaged in the wrap cycle program.

### Zone 2 Remote Console

- 1 EMERGENCY STOP: Red (push off/ turn to reset); turns off all motors, air cylinders and hot wire.
- 2 ZONE 2 CYCLE ENABLE: Green push button; enables Zone 2.
- 3 ZONE 2 CYCLE STOP: Red mushroom push button; stops Zone 2.
- 4 ZONE 2 BYPASS: Black push button: Push to bypass the Stretch wrapper.
- 5 ZONE 2 RESET: White push button; reset Zone 2.
- 6 ZONE 2 POP-UP CONV. Fwd/Auto/Rev: 3-position selector switch; Manually runs the Zone 2 Conveyor. Disengaged in the wrap cycle program.
- 7 ZONE 2 POP-UP CONV. Auto/Raise: 2-position selector switch; Manually raises Zone 2 Conveyor. Disengaged in the wrap cycle program.

### Zone 3 Remote Console

- 1 EMERGENCY STOP: Red (push off/ turn to reset); turns off all motors, air cylinders and hot wire.
- 2 ZONE 3 CYCLE ENABLE: Green push button; enables Zone 3.
- 3 ZONE 3 CYCLE STOP: Red mushroom push button; stops Zone 3.
- 4 ZONE 3 BYPASS: Black push button: Push to bypass the Stretch wrapper.
- 5 ZONE 3 RESET: White push button; reset Zone 3.
- 6 ZONE 3 LOAD. Black push button; Push to load Zone 3.
- 7 ZONE 3 ROLLER CONV. Fwd/Auto/Rev: 3-position selector switch; Manually runs the Zone 3 Conveyor. Disengaged in the wrap cycle program.

### Zone 4 Remote Console

- 1 EMERGENCY STOP: Red (push off/ turn to reset); turns off all motors, air cylinders and hot wire.
- 2 MAIN CYCLE ENABLE: Green push button; enables the wrap cycle.
- 3 MAIN CYCLE STOP: Red mushroom push button; stops the wrap cycle.
- 4 OUTPUT BELT CONV. ADVACNE: Yellow push button. Turns on the Output Conveyor to remove the product from the Winder.
- 5 OUTPUT BELT CONV. STOP: Red push button. Stops the Output Conveyor from unloading from the Winder.

# Operating Instructions

## START UP

- 1 Turn the control cabinet disconnect to ON.
- 2 Check to make sure you have 80 P.S.I. air to the machine.
- 3 Push the POWER ON Green lighted push button. The green power on light will come on.

## FILM LOADING

- 1 Push the blue LOAD FILM button. (The film holders will open)
- 2 Open the film door and load the film as shown in the diagram on page 5.
- 3 Pull the film out and lay it across the film holder.
- 4 Close the film loading door.
- 5 Push the POWER ON button ( the Power On button will light up.)
- 6 Push the white RESET button. (The film holder will close.)
- 7 The system is now ready for the first load.

## WRAP CYCLE

- 1 Push the green CYCLE ENABLE push button.
- 2 After the window is assembled on Zone 1 or Zone 2 the assemble conveyor will bring the window to the stretch wrapper and automatically stretch wrap the window.
- 3 Zone 3- you will need to push the black LOAD push button when the window is read to be stretch wrapped.
- 4 The WINDER will automatically start wrapping the window.
- 5 The INPUT and OUTPUT CONVEYORS will come on and move the product through the WINDER.
- 6 After the window is wrapped the film will be automatically cut.
- 7 After the film is cut the OUTPUT CONVEYOR will come on and remove the window from the WINDER.
- 8 End of wrap cycle.

## General Maintenance

### WARNING!

**MAKE SURE THAT POWER SUPPLY AND AIR SUPPLY IS DISCONNECTED BEFORE ATTEMPTING TO SERVICE ANY COMPONENTS. IF THE POWER DISCONNECT OR AIR DISCONNECT IS OUT OF SIGHT, LOCK IT IN THE OPEN POSITION AND TAG IT**

## Cleaning

Periodically clean dirt accumulations from machine, especially around moving parts and drive components, preferably by vacuuming.

## General

- Check and tighten any loose fasteners.
- Check all electric connections and replace any worn or frayed cords.
- Check all fuses.
- Check all AC drive controllers.
- Check all Photo-eyes and Sensor.
- Make sure the air is on.
- Make sure both film doors are closed.

## Lubrication

### Bearings

- The bearings have been greased at the factory and are ready to run. It is recommended that all mounted bearings and support wheels be relubricated with #3 lithium base grease every three months.

### Chains

- Clean, lubricate and adjust chains every month. Chain should be lubricated with a penetrating type commercial chain lube.

### Gear Reducers

- For new reducers, change the oil 120 hours after the reducer starts operating (based on 8 hours per day of operation). After the first oil change, change oil every 2000 operating hours, or every six months, whichever occurs first.

Temperature	Lubricant
25° - 125° F	AGMA #8
15° - 60° F	AGMA #7

*Certain conditions (dust, water, etc.) may require a change of lubricating periods as dictated by experience.*

## Adjustments

This is automatic system. Do not make adjustments without contacting Kalamazoo Packaging Systems.

## TOUBLESHOOTING

When any problem develops, review the operating instructions. Diagnose specific problems and review the options below.

**Machine not running at all.**

1. Check wall receptacle for power.
2. Check the air supply.
3. Check all cord for cut. (Fork Lift Trucks damage cords.)
4. Check all fuses and/or breakers.
5. Check AC drive for faults.
6. Check all limit switches and sensors for damage, sticking or internal shorts.
7. Open cabinet and check that all relays are firmly seated in their bases.
8. Visually inspect for loose wires and for any signs of arcing or burning of any of the components.
9. The film door must be shut before the winder will run.
10. Winder ring noises, use taping wax around ring edge.
11. It is advisable to call for technical assistance at this time. (616) 534-2600.

**Technical and Customer Service is available from Kalamazoo Packaging Systems, Inc., Monday thru Friday 7:30 A.M. to 4:00 P.M. (EST). Stock is maintained on parts to allow us to ship the same day on most orders.**

**If you have a problem, we want to know about it!  
Please call and report any difficulties you may encounter.**

- Local - (616) 534-2600
- National - (800) 253-4625

## Allen-Bradley MicroFlex 4 AC DRIVE PROGRAMMING

### Swing Out Conveyor (1hp)

P035	60.0	HSP
P036	2	START SOURCE DI1
P038	1	EXTERNAL POT.
P039	0.1	ACCEL TIME
A040	0.1	DECEL TIME
A067	0.1	ACCEL 1 TIME
A068	0.1	DECEL 1 TIME
A072	8.9	MULTISPEED 2 (DECEL)

### Input Belt Conveyor (1hp)

P035	60.0	HSP
P036	2	START SOURCE DI1
P038	1	EXTERNAL POT.
P039	0.1	ACCEL TIME
A040	0.1	DECEL TIME
A067	0.1	ACCEL 1 TIME
A068	0.1	DECEL 1 TIME
A072	35.0	MULTISPEED 2 (DECEL)

### Zone 1 Pop-Up Conveyor (1hp)

P035	60.0	HSP
P036	2	START SOURCE DI1
P038	1	EXTERNAL POT.
P039	0.1	ACCEL TIME
A040	0.1	DECEL TIME
A067	0.1	ACCEL 1 TIME
A068	0.1	DECEL 1 TIME
A072	8.9	MULTISPEED 2 (DECEL)

### Winder (3hp)

P035	30.0	HSP
P036	2	START SOURCE DI1
P038	1	EXTERNAL POT.
P039	3.0	ACCEL TIME
A040	1.5	DECEL TIME
A067	3.0	ACCEL 1 TIME
A068	1.5	DECEL 1 TIME
A072	10	MULTISPEED 2 (DECEL)

### Band Roller Conveyor (1hp)

P035	47.0	HSP
P036	2	START SOURCE DI1
P038	1	EXTERNAL POT.
P039	0.1	ACCEL TIME
A040	0.1	DECEL TIME
A067	0.1	ACCEL 1 TIME
A068	0.1	DECEL 1 TIME
A072	35.0	MULTISPEED 2 (DECEL)

### Output Belt Conveyor (1hp)

P035	60.0	HSP
P036	2	START SOURCE DI1
P038	1	EXTERNAL POT.
P039	0.1	ACCEL TIME
A040	0.1	DECEL TIME
A067	0.1	ACCEL 1 TIME
A068	0.1	DECEL 1 TIME
A072	35.0	MULTISPEED 2 (DECEL)

### Zone 2 Pop-Up Conveyor (1hp)

P035	60.0	HSP
P036	2	START SOURCE DI1
P038	1	EXTERNAL POT.
P039	0.1	ACCEL TIME
A040	0.1	DECEL TIME
A067	0.1	ACCEL 1 TIME
A068	0.1	DECEL 1 TIME
A072	8.9	MULTISPEED 2 (DECEL)

# Kalamazoo Packaging Systems Model # 862FA-D12

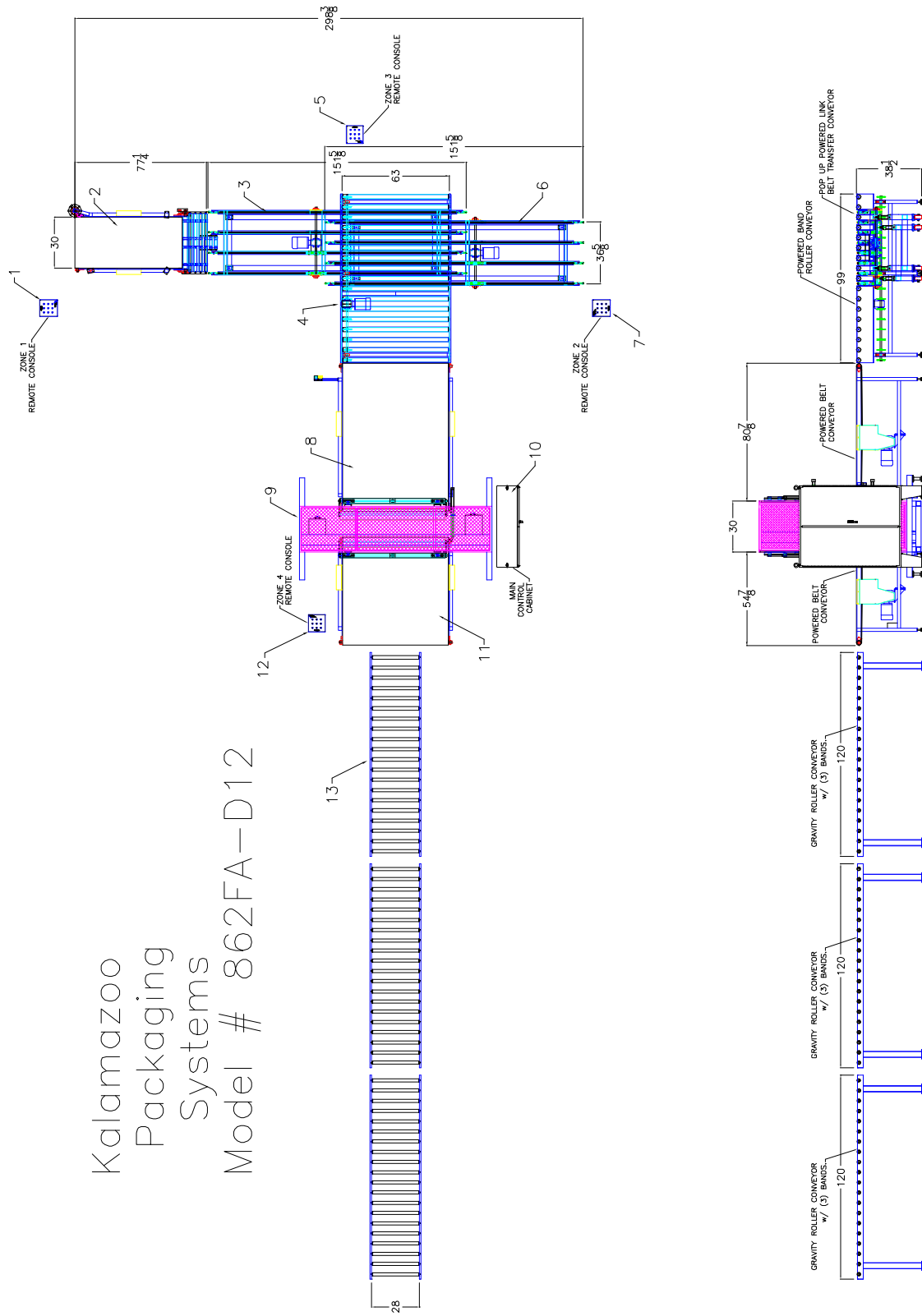

# PARTS MANUAL: 862FA-D12 LAYOUT

ITEM	DESCRIPTION	PAGE#	QTY
1	ZONE 1 REMOTE CONSOLE	14-15	1
2	SWING AWAY BELT CONVEYOR	16-19	1
3	ZONE 1 POP-UP BAND BELT CONVEYOR	20-22	1
4	BAND ROLLER CONVEYOR	23-28	1
5	ZONE 3 REMOTE CONSOLE	29-30	1
6	ZONE 2 POP-UP BAND BELT CONVEYOR	31-33	1
7	ZONE 2 REMOTE CONSOLE	34-35	1
8	INPUT BELT CONVEYOR	36-44	1
9	862FA-D12 DUAL 12" FILM HORIZONTAL WINDER	45-54	1
10	MAIN CONTROL CABINET	55-65	1
11	OUTPUT BELT CONVEYOR	66-68	1
12	ZONE 4 REMOTE CONSOLE	69-70	1
12	OUTPUT GRAVITY ROLLER CONVEYORS	71	3

Kalamazoo  
Packaging  
Systems  
ZONE 1 REMOTE CONSOLE

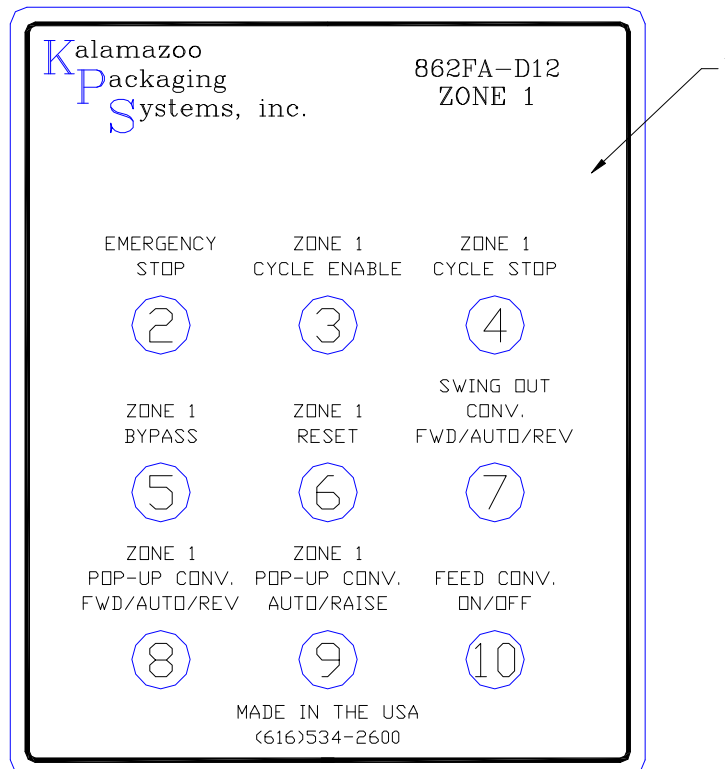

## Kalamazoo Packaging Systems PARTS MANUAL: ZONE 1 REMOTE CONSOLE

ITEM	DWG.# /PART #	DESCRIPTION	QTY
1	D-862FA-D12-ZONE1	ZONE 1 REMOTE CONTROL DECAL	1
2	2071100	PUSH OFF/ TURN TO RESET (E-STOP)	1
3	2070010	GREEN PUSH BUTTON (CYCLE ENABLE)	1
4	2070500	RED MUSHROOM BUTTOM (CYCLE STOP)	1
5	2070600	BLACK PUSH BUTTON (BYPASS)	1
6	2070570	WHITE PUSH BUTTON (RESET)	1
7	2071030	3-POS. SELECTOR (SWING OUT CONV. FWD/AUTO/REV)	1
8	2071030	3-POS. SELECTOR (ZONE 1 POP-UP CONV. FWD/AUTO/REV)	1
9	2071000	2-POS. SELECTOR (ZONE 1 POP-UP CONV. AUTO/RAISE)	1
10	2071000	2-POS. SELECTOR (FEED CONV. ON/OFF )	1

Kalamazoo  
 Packaging  
 Systems  
 Swing Away Conveyor  
 Model # 830PB60-38TLC-SA

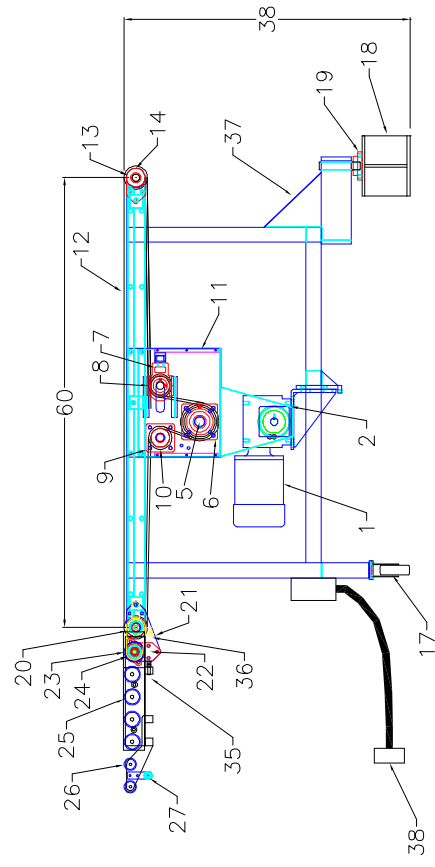
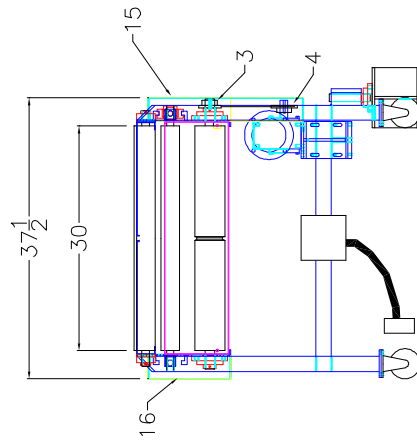
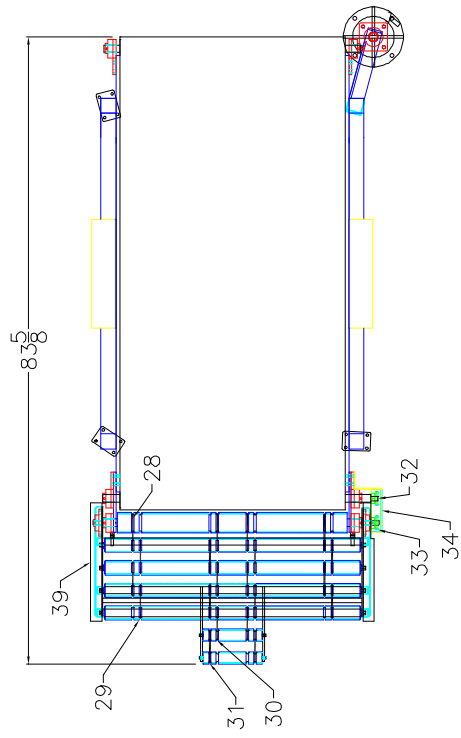

**Kalamazoo Packaging Systems**  
**PARTS MANUAL: Swing Out Conveyor**  
**830PB60-38TLC-SA**

ITEM	DWG.# /PART #	DESCRIPTION	QTY
1	1055520	MOTOR	1
2	1063500T	R/A REDUCER	1
3	1080160-1	DRIVEN SPROCKET (50B16x1")	1
4	108300-1	DRIVE SPROCKET (50B18x1")	1
5	1211400	1" 4-BOLT FLANGE BEARING	2
6	PB-830PB-4-1-DR	4" DRIVE ROLLER	1
7	PB-830-2.5TUR	2-1/2" TAKE-UP ROLLER	1
8	1210620	1" TAKE-UP BEARING	2
9	PB-830-2.5TUR	2-1/2" TAKE-UP ROLLER	1
10	1211400	1" 4-BOLT FLANGE BEARING	2
11	PB-DRC-30	DRIVE ROLLER END COVER	2
12	PB-30x60-BELT	830PB60 BELT (BLACK RUFF TOP)	1
13	1210540	1" CHEVRON BEARING	4
14	PB-830-2.5EIR	2-1/2" END IDLER ROLLER	2
15	PB-LDRG	DRIVE SIDE GUARD	1
16	PB-RDRG	DRIVEN SIDE GUARD	1
17	1222020	4"x 1-1/4" RIGID CASTERS	3
18	830PB60-38C-SA-05	SWING OUT CONVEYOR BEARING MOUNT	1
19	1211400	1" 4-BOLT FLANGE BEARING	1
20	PB-830-2.5EIR	2-1/2" END DRIVE ROLLER	1
21	830PB60-38RC-SA-CP	LIFT GATE CONNECTING PLATE	2
22	1210540	1" CHEVRON BEARING	2
23	830PB60-38RC-SA-2.5R	2-1/2" BAND DRIVE ROLLER	1
24	1210400	5/8" 2-BOLT FLANCE BEARING	2

**Kalamazoo Packaging Systems**  
**PARTS MANUAL: Swing Out Conveyor**  
**830PB60-38TLC-SA**

ITEM	DWG.# /PART #	DESCRIPTION	QTY
25	830PB60-38RC-SA-1.9R	1.9" BAND DRIVEN ROLLER	4
26	830PB60-38RC-SA-1.3R	1-3/8" BAND DRIVEN ROLLER	2
27	830PB60-38RC-SA-GRCLS	LIFT GATE LOCK SHAFT	1
28	2809010	3/16"x 10.57 RED 90A O-RING BELT	4
29	2809015	3/16"x 9.29 RED 90A O-RING BELT	12
30	2809020	3/16"x 8.92 RED 90A O-RING BELT	2
31	2809025	3/16"x 8.53 RED 90A O-RING BELT	2
32	1075750	ROLLER DRIVE SPROCKET (35B10x5/8)	1
33	1075750	ROLLER DRIVEN SPROCKET (35B10x5/8)	1
34	830PB60-38RC-SA-GRCDG	ROLLER DRIVE CHAIN GUARD	1
35	2131782	PRODUCT SENSOR SCANNER DIFFUSED	1
35	2132010	PRODUCT SENSOR CABLE	1
36	2108550	LIFT GATE LIMIT SWITCH	1
37	2108550	SWING AWAY LIMIT SWITCH	1
38	2103140	32-PIN HOOD 90 DEGRESS	1
38	2103141	^ PLUG 1-16 (see next page for pin numbers)	1
38	2103142	^ PLUG 17-32 (see next page for pin numbers)	1
38	830PB60-38RC-SA-APB	ADDON PLASTIC BLOCKS	2

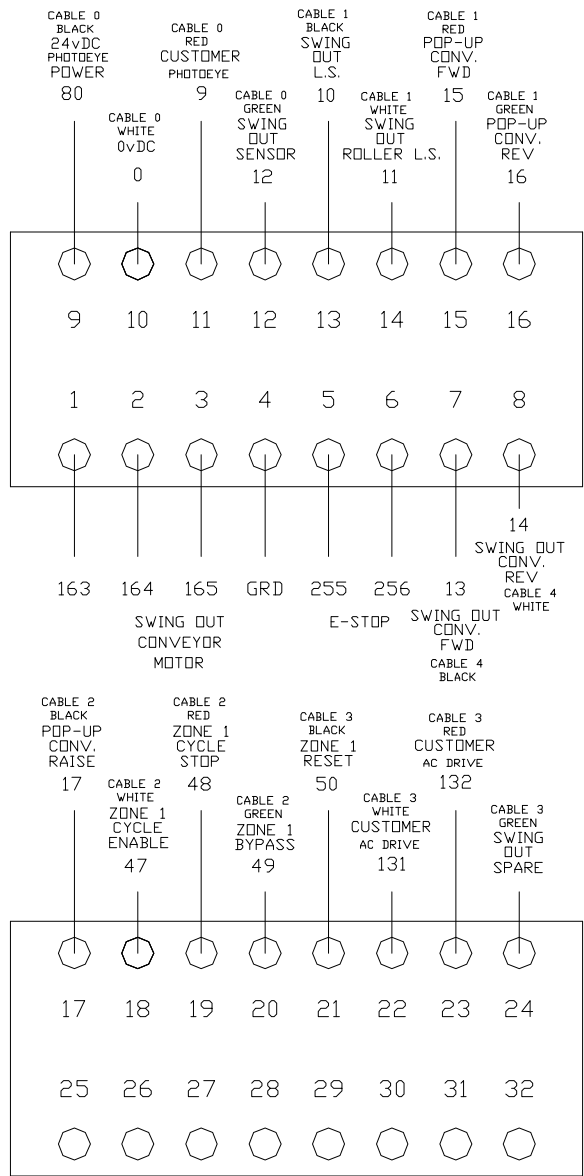

(A) SWING OUT CONV.  
1-16 32-PIN CONNECTOR

(A) SWING OUT CONV.  
17-32 32-PIN CONNECTOR

Kalamazoo  
Packaging  
Systems  
Band Belt  
ZONE 1 Pop-up Conveyor  
Model # 36-4BBC145-ZONE1

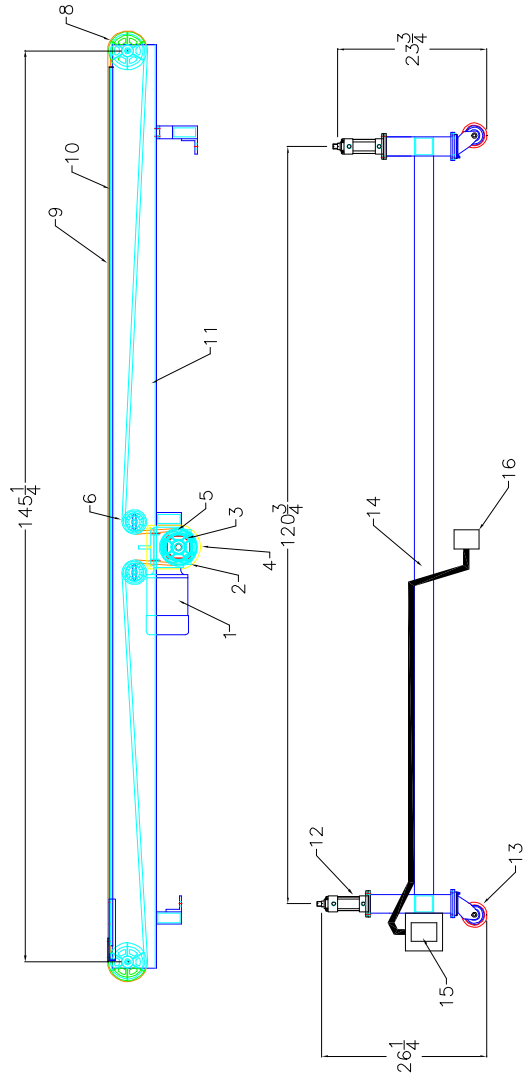
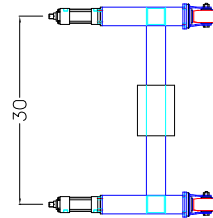
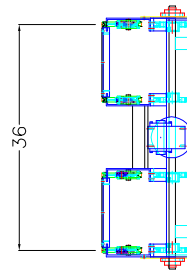
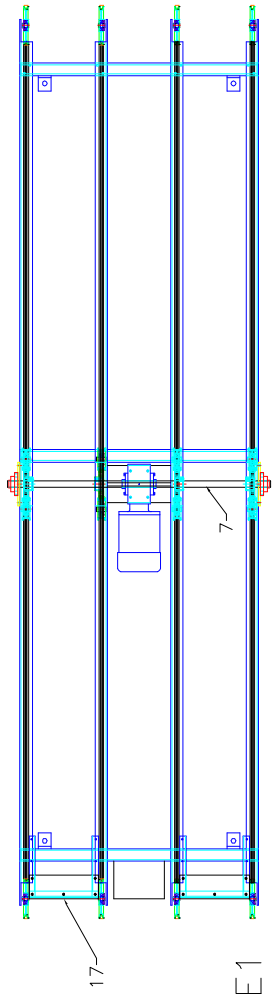

**Kalamazoo Packaging Systems**  
**PARTS MANUAL: ZONE 1 Band Belt Pop-up Conveyor**  
**36-4BBC145-ZONE1**

ITEM	DWG.# /PART #	DESCRIPTION	QTY
1	1055520	MOTOR	1
2	1063191	R/A REDUCER	1
3	1211400	1" 4-BOLT FLANGE BEARING	2
4	36-4BBC145x38-03	DRIVE SHAFT BEARING SUPPORT PLATE	2
5	2810020	BAND BELT 4-3/4" DRIVE PULLEY 1" FINISH BORE	4
6	2810030	BAND BELT 3-1/2" FLAT IDLER PULLEY	8
7	36-4BBC145x38-DS	BAND BELT DRIVE SHAFT	1
8	2810040	BAND BELT 6" END IDLER PULLEY	8
9	2810000	BAND BELT 507 LINKS #A/4L BELTING	4
10	2810010	NYLON V-BELT GUIDE	4
11	36-4BBC145x38-TF-RA	BAND BELT CONVEYOR TOP FRAME	1
12	2810050	BAND BELT LIFT CYLINDER	4
12	2800055	SOLID STATE SWITCH	1
12	2800054	SWITCH BRACKET	1
13	1222600	4" x 2" SWIVEL CASTER	4
14	36-4BBC145x38-RBF	ZONE 1 BAND BELT BASE FRAME	1
15	2103143	32-PIN BASE	1
15	2103144	RECEPTACLE 1-16	1
15	2103145	RECEPTACLE 17-32	1
16	2103140	32-PIN HOOD 90 DEGRESS	1
16	2103141	^ PLUG 1-16 (see next page for pin numbers)	1
16	2103142	^ PLUG 17-32 (see next page for pin numbers)	1
17	36-4BBC145x38-Z1ASP	ZONE 1 ADD-ON SLIDE PLATES	2

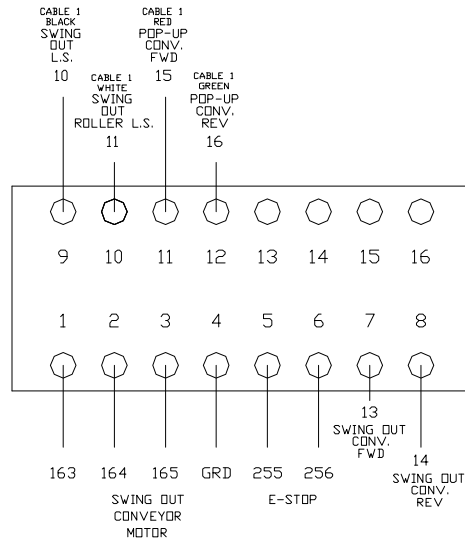
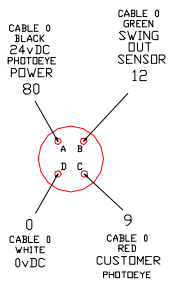

(A) ZONE 1 POP-UP CONV.  
1-16 32-PIN CONNECTOR

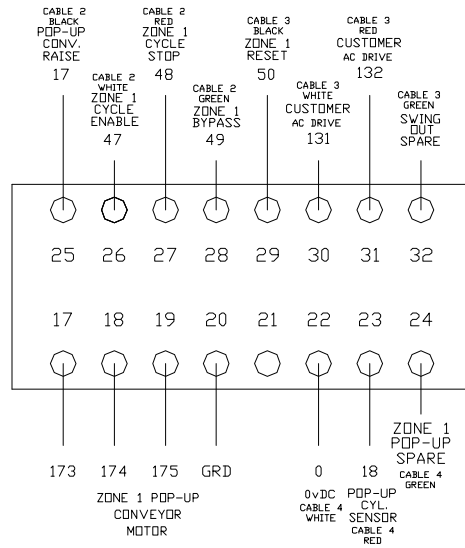

(A) ZONE 1 POP-UP CONV.  
17-32 32-PIN CONNECTOR

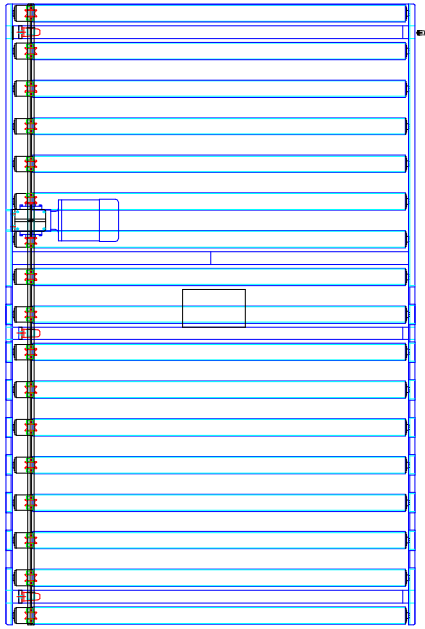

Kalamazoo  
Packaging  
Systems  
63"X99" BAND ROLLER CONVEYOR  
Model #63BRC99X38.5

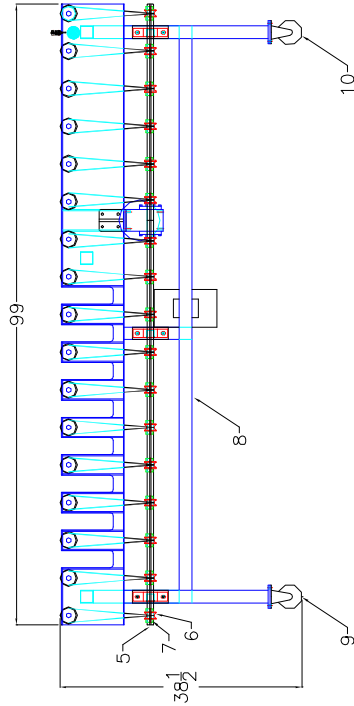
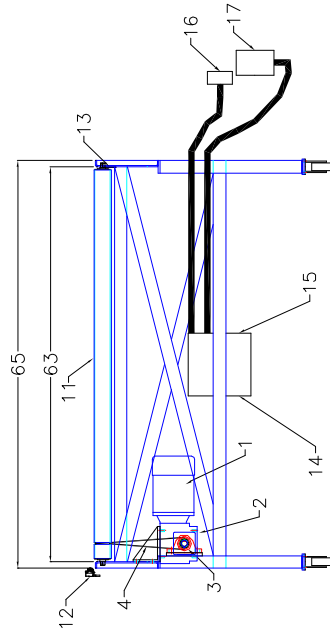

## Kalamazoo Packaging Systems

### PARTS MANUAL: Band Roller Conveyor 63BRC99x38.5

ITEM	DWG.# /PART #	DESCRIPTION	QTY
1	1055520	MOTOR	1
2	1065940T	R/A REDUCER	1
3	1212500	1" PILLOW BLOCK BEARING	3
4	2809000	3/16"x 27.92 RED 90A O-RING BELT	17
5	63BRC99x38.5-05-RA	BAND ROLLER CONVEYOR DRIVE SHAFT	1
6	2810100	2" KEYED SPOOL w/ 1" FINISH BORE	17
7	2810101	C-CLIP FOR SPOOL FOR 1" SHAFT	32
8	63BRC99x38.5-06	63BRC99x38.5 BAND ROLLER CONVEYOR FRAME	1
9	1222000	4" x 1-1/4" TOTAL LOCK SWIVEL CASTER	2
10	1222020	4" x 1-1/4" RIGID CASTER	2
11	63BRC99x38.5-R	2-1/2" DIA. BAND CONVEYOR ROLLER w/ COVER	17
12	2131795	PRODUCT SENSOR	1
12	2131796	PRODUCT SENSOR CABLE	1
13	2131820	PRODUCT SENSOR REFLECTOR	1
14	2103143	32-PIN BASE	1
14	2103144	^ RECEPTACLE 1-16 (see next page for pin numbers)	1
14	2103145	^ RECEPTACLE 17-32 (see next page for pin numbers)	1
15	2103132	24-PIN BASE	1
15	2103133	^ RECEPTACLE 1-24 (see page 26 for pin numbers)	1
16	2103139	32-PIN HOOD STR.	1
16	2103141	^ PLUG 1-16 (see page 27 for pin numbers)	1
16	2103142	^ PLUG 17-32 (see page 27 for pin numbers)	1
17	2133151	48-PIN HOOD 90 DEGRESS	1
17	2133152	^ PLUG 1-24 (see page 28 for pin numbers)	1
17	2133153	^ PLUG 25-48 (see page 28 for pin numbers)	1

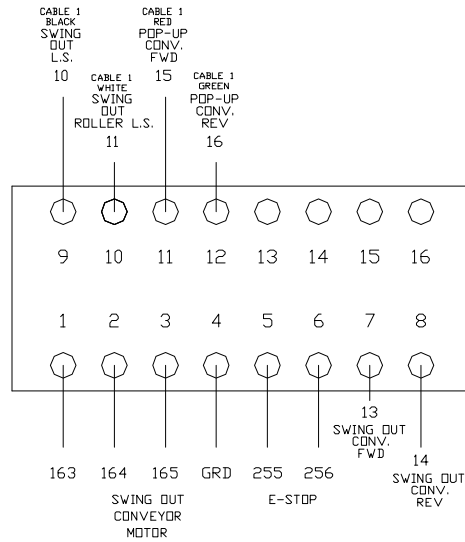
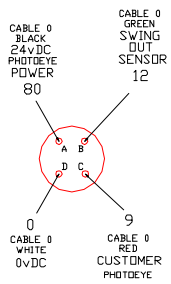

(A) ZONE 1 POP-UP CONV.  
1-16 32-PIN CONNECTOR

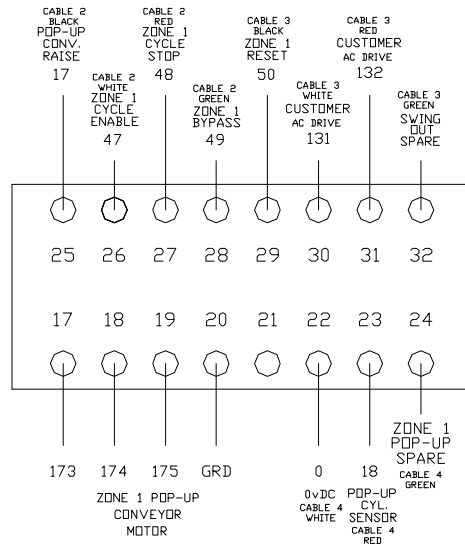

(A) ZONE 1 POP-UP CONV.  
17-32 32-PIN CONNECTOR

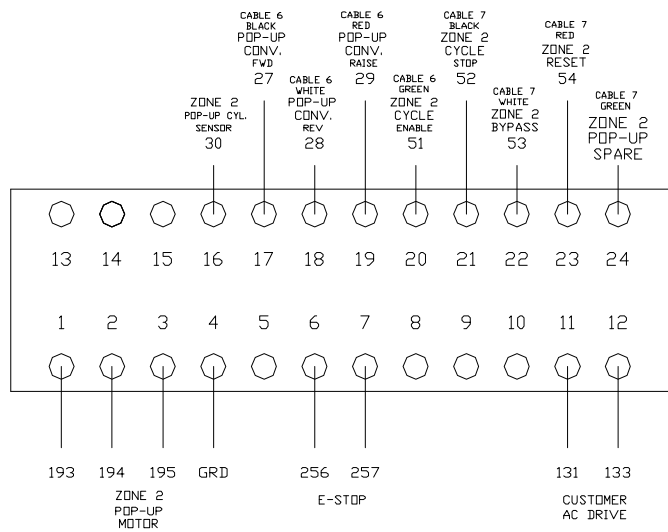
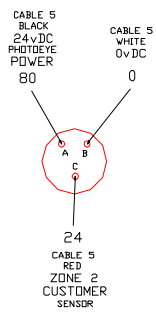

POP-UP ZONE 2  
24-PIN CONNECTOR

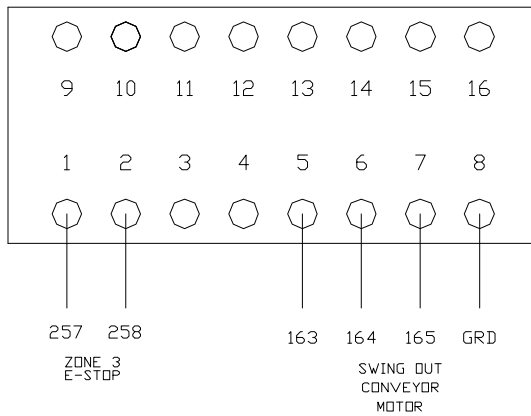

(A) ZONE 3 INPUT CONV.  
1-16 32-PIN CONNECTOR

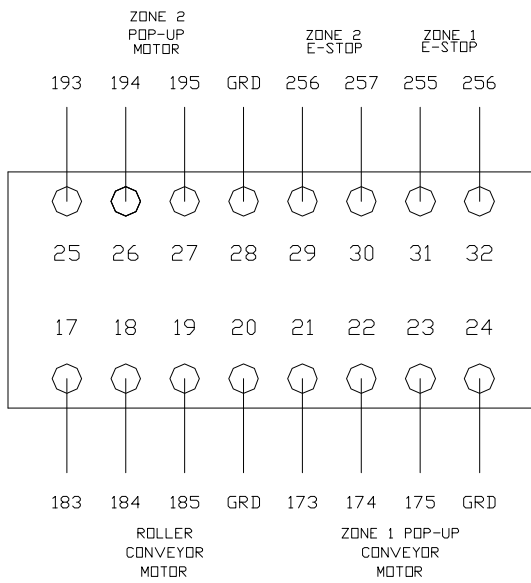

(A) ZONE 3 INPUT CONV.  
17-32 32-PIN CONNECTOR

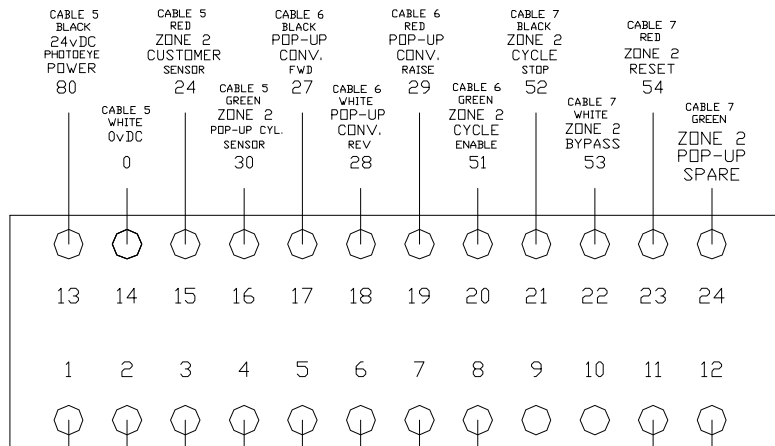

(A) ZONE 3 INPUT CONV.  
48-PIN CONNECTOR  
PINS 1-24

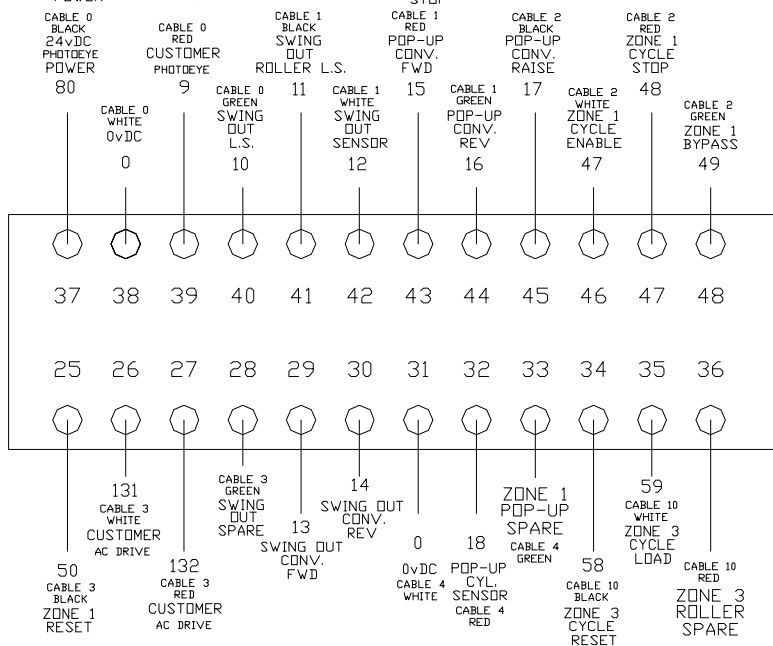

(A) ZONE 3 INPUT CONV.  
48-PIN CONNECTOR  
PINS 25-48

Kalamazoo  
Packaging  
Systems  
ZONE 3 REMOTE CONSOLE

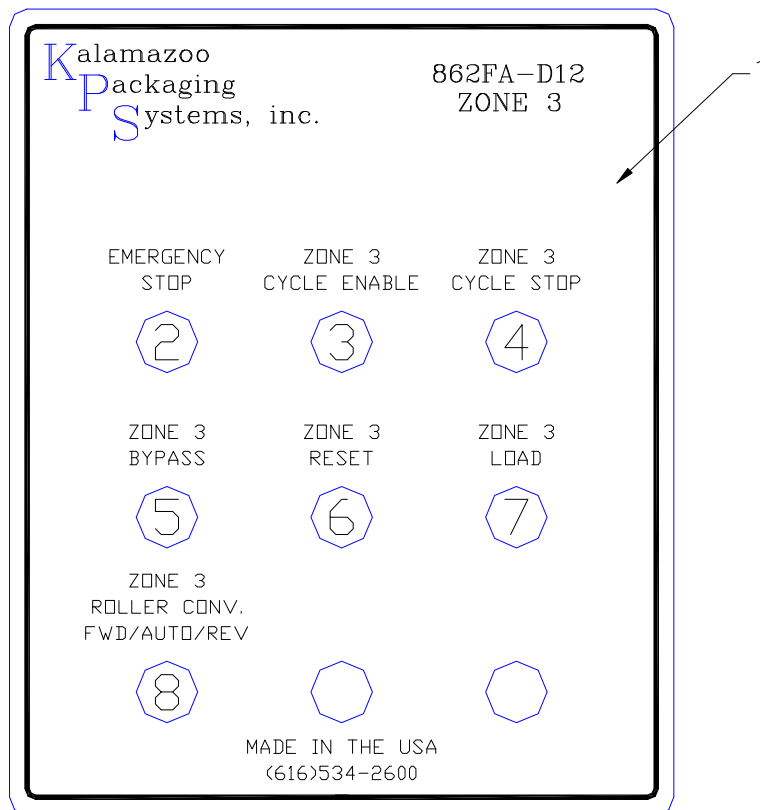

**Kalamazoo Packaging Systems**  
**PARTS MANUAL: ZONE 3 REMOTE CONSOLE**

ITEM	DWG.# /PART #	DESCRIPTION	QTY
1	D-862FA-D12-ZONE3	ZONE 3 REMOTE CONTROL DECAL	1
2	2071100	PUSH OFF/ TURN TO RESET (E-STOP)	1
3	2070010	GREEN PUSH BUTTON (CYCLE ENABLE)	1
4	2070500	RED MUSHROOM BUTTOM (CYCLE STOP)	1
5	2070600	BLACK PUSH BUTTON (BYPASS)	1
6	2070570	WHITE PUSH BUTTON (RESET)	1
7	2070600	BLACK PUSH BUTTON (LOAD)	1
8	2071030	3-POS. SELECTOR (ZONE 3 ROLLER CONV. FWD/AUTO/REV)	1

Kalamazoo  
 Packaging  
 Systems  
 Band Belt  
 ZONE 2 Pop-up Conveyor  
 Model # 36-4BBC145-ZONE2

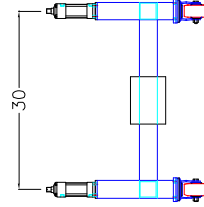
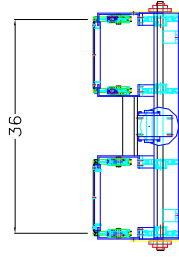
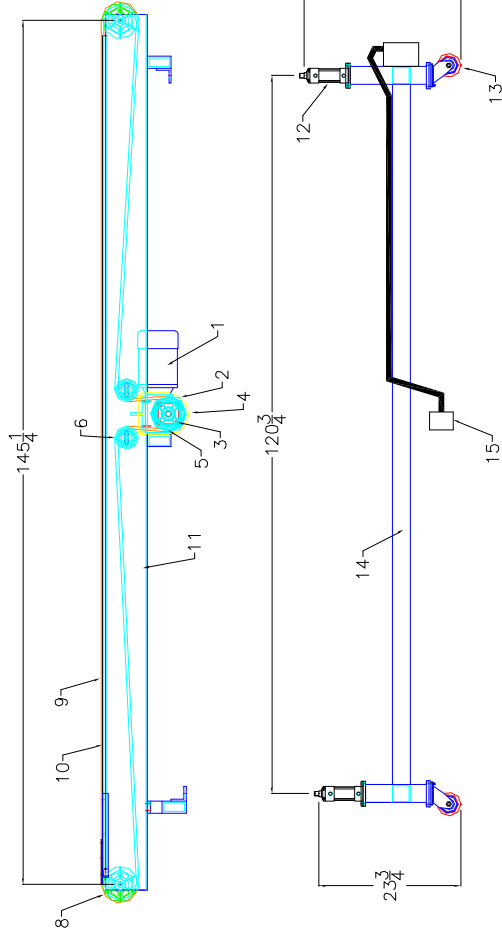
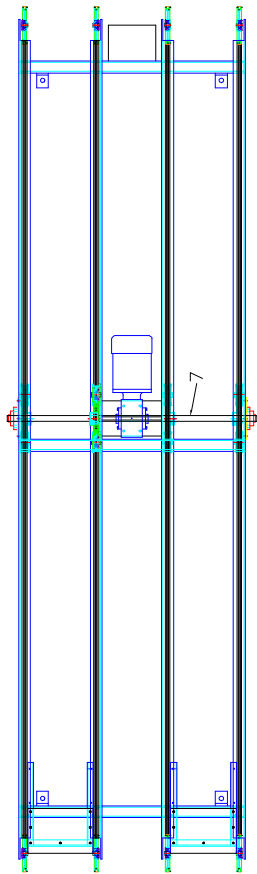

**Kalamazoo Packaging Systems**  
**PARTS MANUAL: ZONE 2 Band Belt Pop-up Conveyor**  
**36-4BBC145-ZONE2**

ITEM	DWG.# /PART #	DESCRIPTION	QTY
1	1055520	MOTOR	1
2	1063191	R/A REDUCER	1
3	1211400	1" 4-BOLT FLANGE BEARING	2
4	36-4BBC145x38-03	DRIVE SHAFT BEARING SUPPORT PLATE	2
5	2810020	BAND BELT 4-3/4" DRIVE PULLEY 1" FINISH BORE	4
6	2810030	BAND BELT 3-1/2" FLAT IDLER PULLEY	8
7	36-4BBC145x38-DS	BAND BELT DRIVE SHAFT	1
8	2810040	BAND BELT 6" END IDLER PULLEY	8
9	2810000	BAND BELT 507 LINKS #A/4L BELTING	4
10	2810010	NYLON V-BELT GUIDE	4
11	36-4BBC145x38-TF-RA	BAND BELT CONVEYOR TOP FRAME	1
12	2810050	BAND BELT LIFT CYLINDER	4
12	2800055	SOLID STATE SWITCH	1
12	2800054	SWITCH BRACKET	1
13	1222600	4" x 2" SWIVEL CASTER	4
14	36-4BBC145x38-LBF	ZONE 2 BAND BELT BASE FRAME	1
15	2103130	24-PIN HOOD STR.	1
15	2103131	^ PLUG 1-24 (see next page for pin numbers)	1
16	36-4BBC145x38-Z2ASP	ZONE 2 ADD-ON SLIDE PLATE	2

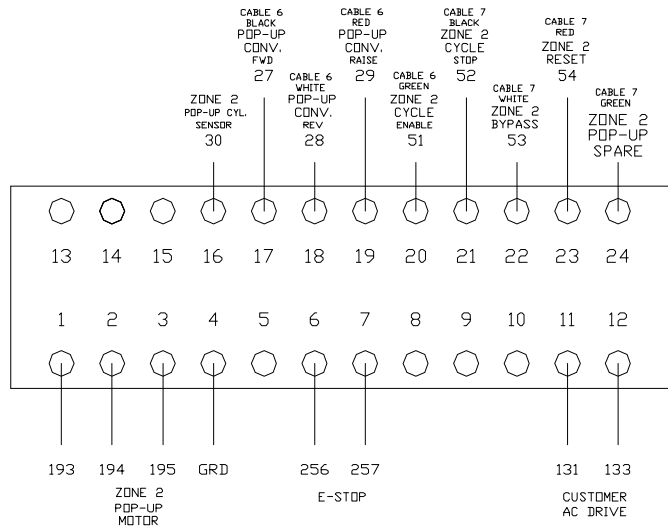
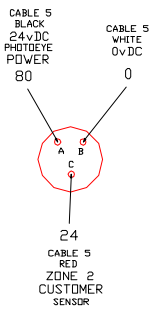

POP-UP ZONE 2  
24-PIN CONNECTOR

Kalamazoo  
Packaging  
Systems  
ZONE 2 REMOTE CONSOLE

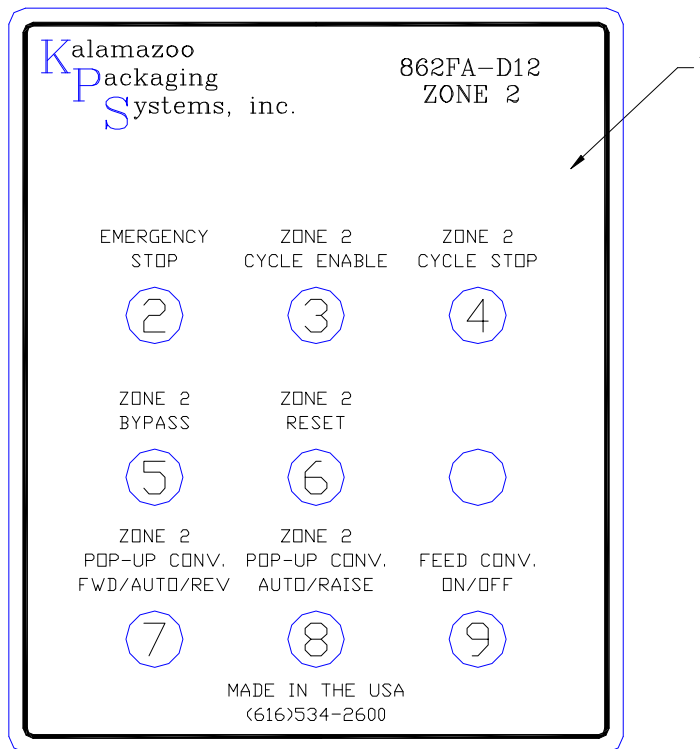

## Kalamazoo Packaging Systems PARTS MANUAL: ZONE 2 REMOTE CONSOLE

ITEM	DWG.# /PART #	DESCRIPTION	QTY
1	D-862FA-D12-ZONE2	ZONE 2 REMOTE CONTROL DECAL	1
2	2071100	PUSH OFF/ TURN TO RESET (E-STOP)	1
3	2070010	GREEN PUSH BUTTON (CYCLE ENABLE)	1
4	2070500	RED MUSHROOM BUTTOM (CYCLE STOP)	1
5	2070600	BLACK PUSH BUTTON (BYPASS)	1
6	2070570	WHITE PUSH BUTTON (RESET)	1
7	2071030	3-POS. SELECTOR (ZONE 2POP-UP CONV. FWD/AUTO/REV)	1
8	2071000	2-POS. SELECTOR (ZONE 2 POP-UP CONV. AUTO/RAISE)	1
9	2071000	2-POS. SELECTOR (FEED CONV. ON/OFF)	1

Kalamazoo  
 Packaging  
 Systems  
 INPUT BELT CONVEYOR  
 Model # 862PB84-38.5TLC-NMF

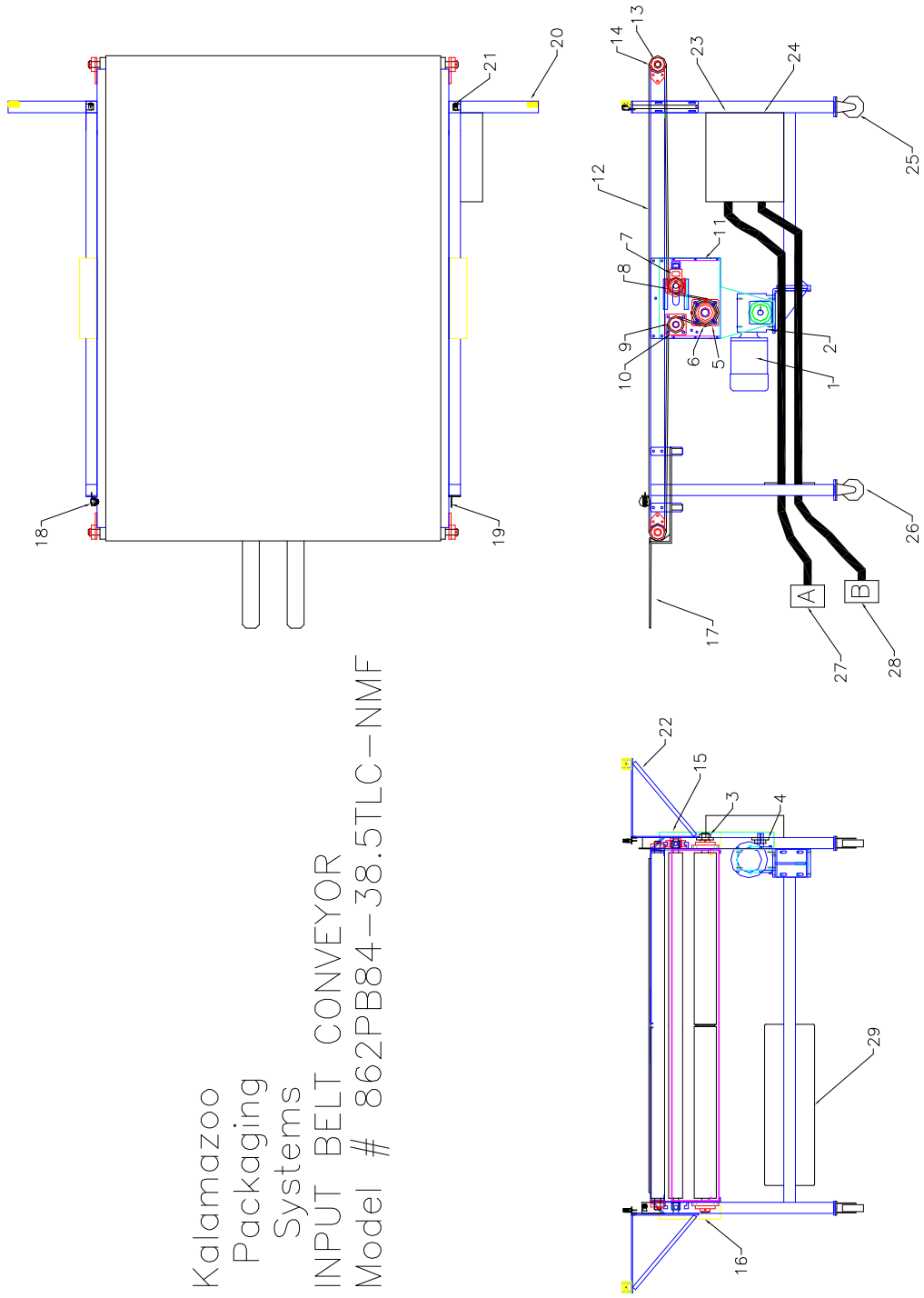

**Kalamazoo Packaging Systems**  
**PARTS MANUAL: INPUT BELT CONVEYOR**  
**826PB84-38.5TLC-NMF**

ITEM	DWG.# /PART #	DESCRIPTION	QTY
1	1055520	MOTOR	1
2	1063500T	R/A REDUCER	1
3	1080160-1.25	DRIVEN SPROCKET (50B16x1-1/4")	1
4	1080500	DRIVE SPROCKET (50B20x1")	1
5	1211500	1-1/4" 4-BOLT FLANGE BEARING	2
6	PB-862PB-4-1.25-DR	4" DRIVE ROLLER	1
7	PB-862-2.5TUR	2-1/2" TAKE-UP ROLLER	1
8	1210620	1" TAKE-UP BEARING	2
9	PB-862-2.5TUR	2-1/2" TAKE-UP ROLLER	1
10	1211400	1" 4-BOLT FLANGE BEARING	2
11	PB-DRC-62	DRIVE ROLLER END COVER	2
12	PB-60x84-BELT	860PB84 BELT (BLACK RUFF TOP)	1
13	1210540	1" CHEVRON BEARING	4
14	PB-862-2.5EIR	2-1/2" END IDLER ROLLER	2
15	PB-LDRG	DRIVE SIDE GUARD	1
16	PB-RDRG	DRIVEN SIDE GUARD	1
17	862PB84-38.5-NMF	DAUL NON-MOVABLE PRODUCT FORKS	1
18	2131780	PRODUCT SENSOR	1
18	2132010	PRODUCT SENSOR CABLE	1
18	2131785	VERT. STEEL MOUNTING BRACKET	1
19	2131820	PRODUCT SENSOR REFLECTOR	1

**Kalamazoo Packaging Systems**  
**PARTS MANUAL: INPUT BELT CONVEYOR**  
**862PB84-38.5TLC-NMF**

ITEM	DWG.# /PART #	DESCRIPTION	QTY
20	2131780	PRODUCT SENSOR	2
20	2132010	PRODUCT SENSOR CABLE	2
20	2131786	Q18 PLASTIC MOUNTING BRACKET	2
21	2131780	PRODUCT SENSOR	2
21	2132010	PRODUCT SENSOR CABLE	2
21	2131785	VERT. STEEL MOUNTING BRACKET	2
22	862PB84-38.5-LSM	SENSOR MOUNTING BRACKET	2
23	2103133	32-PIN BASE	1
23	2103134	^ RECEPTACLE 1-16 (see next page for pin numbers)	1
23	2103135	^ RECEPTACLE 17-32 (see next page for pin numbers)	1
24	2103154	48-PIN BASE	1
24	2133155	^ RECEPTACLE 1-24 (see page 40 for pin numbers)	1
24	2133156	^ RECEPTACLE 25-48 (see page 40 for pin numbers)	1
25	1222000	4" x 1-1/4" TOTAL LOCK SWIVEL CASTER	2
26	1222020	4" x 1-1/4" RIGID CASTER	2
27	2103151	48-PIN HOOD 90 DEGRESS (A)	1
27	2103151	^ PLUG 1-24 (A) (see page 41 for pin numbers)	1
27	21031453	^ PLUG 25-48 (A) (see page 41 for pin numbers)	1
28	2103151	48-PIN HOOD 90 DEGRESS (B)	1
28	2103152	^ PLUG 1-24 (B) (see page 42 for pin numbers)	1
28	2103153	^ PLUG 25-48 (B) (see page 42 for pin numbers)	1
29	(SEE NEXT PAGE)	AIR SYSTEM VALVE BANK	

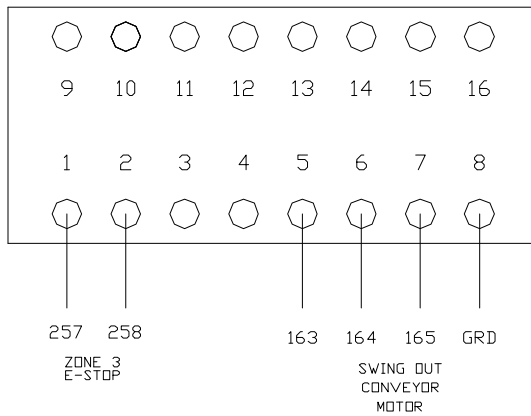

(A) ZONE 3 INPUT CONV.  
1-16 32-PIN CONNECTOR

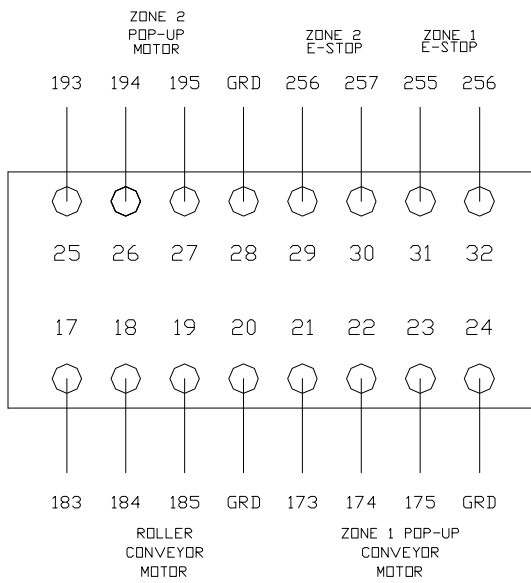

(A) ZONE 3 INPUT CONV.  
17-32 32-PIN CONNECTOR

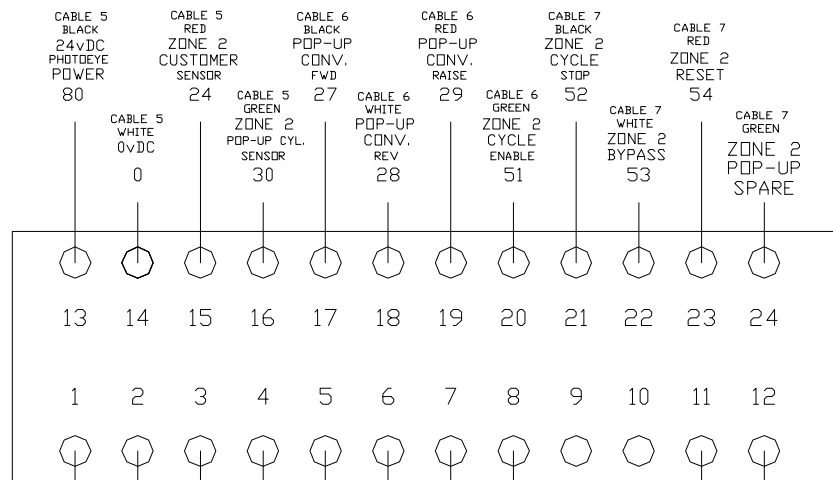

(A) ZONE 3 INPUT CONV.  
48-PIN CONNECTOR  
PINS 1-24

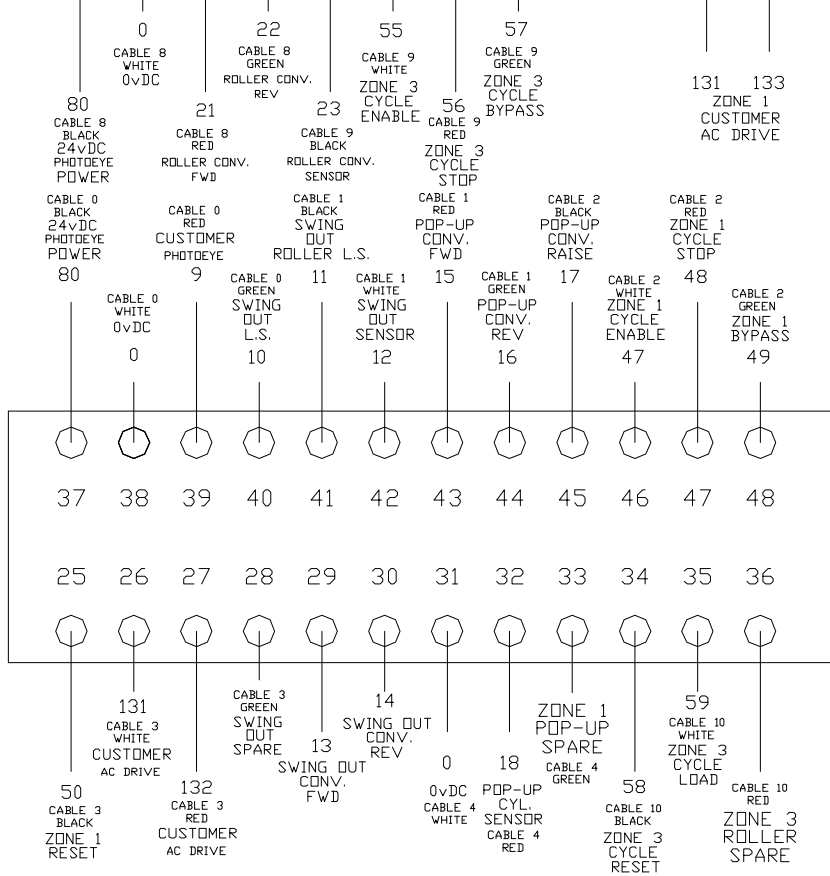

(A) ZONE 3 INPUT CONV.  
48-PIN CONNECTOR  
PINS 25-48

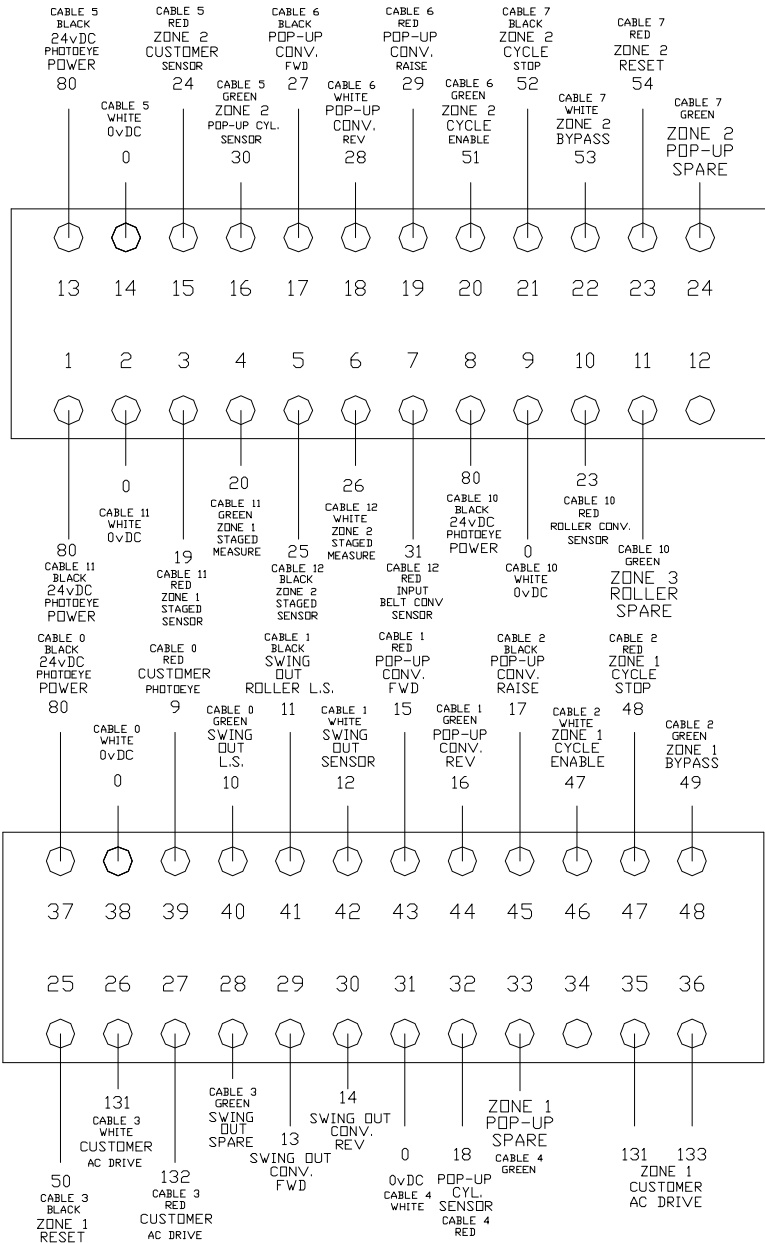

(A) INPUT SIDE  
48-PIN CONNECTOR  
PINS 1-24

(A) INPUT SIDE  
48-PIN CONNECTOR  
PINS 25-48

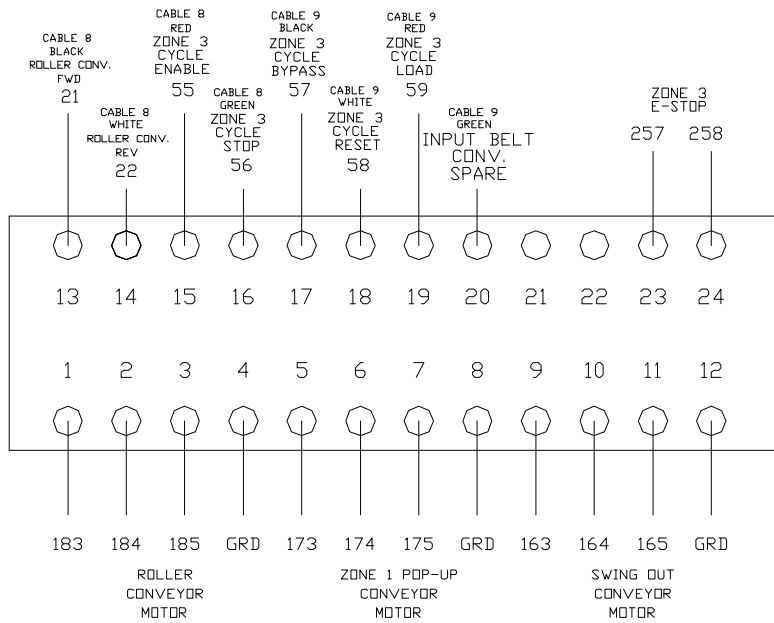

(B) INPUT SIDE  
48-PIN CONNECTOR  
PINS 1-24

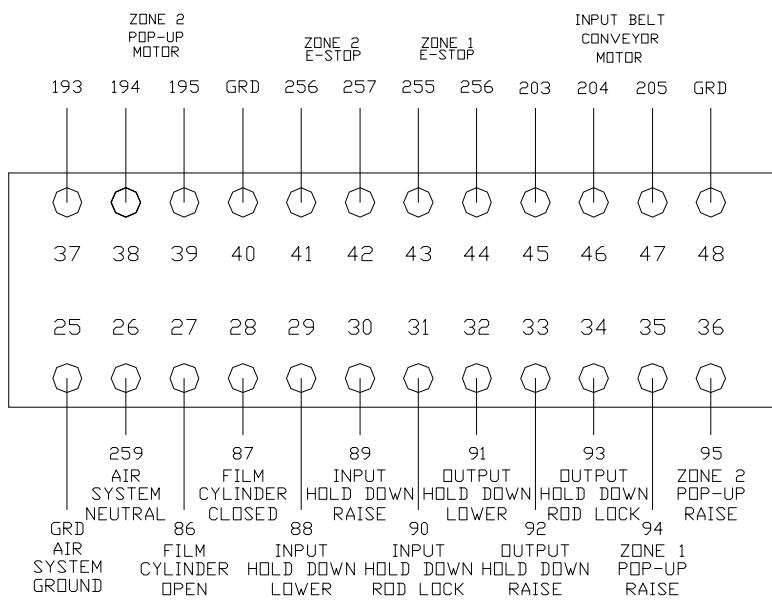

(B) INPUT SIDE  
48-PIN CONNECTOR  
PINS 25-48

1 2 3 4 5 6 7 8

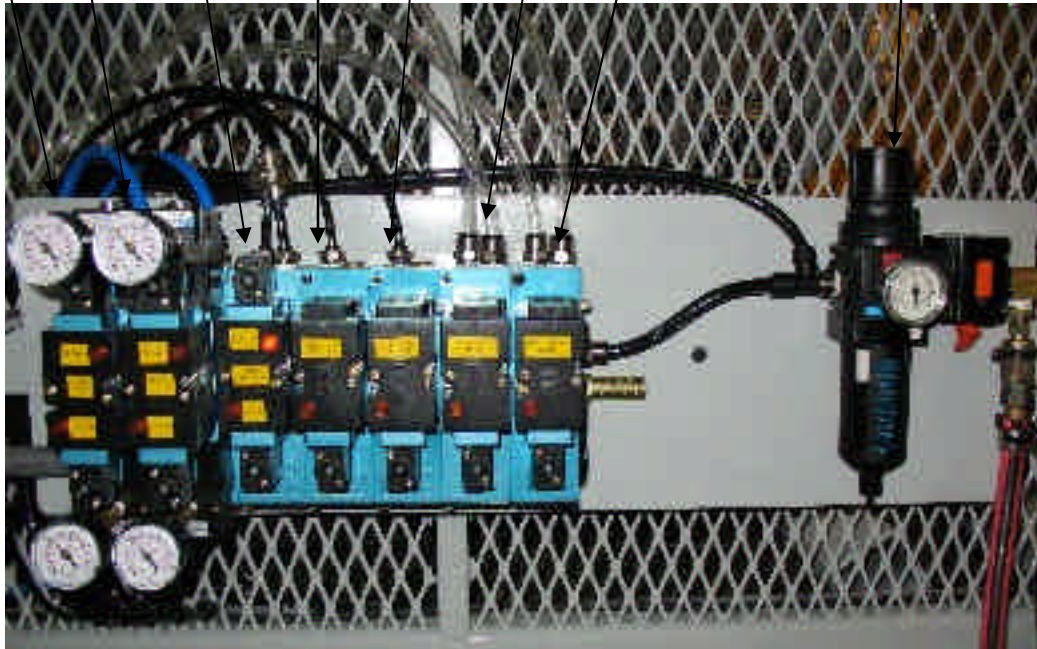

**PARTS MANUAL:  
862FA-D12 AIR SYSTEM VALVE ASSEMBLY**

<b>ITEM</b>	<b>PART #/DWG. #</b>	<b>DESCRIPTION</b>	<b>QTY</b>
1		INPUT HOLD DOWN RETACT	1
2		OUTPUT HOLD DOWN RETACT	1
3		FILM CUT OFF CYLINDER	2
4		INPUT HOLD DOWN ROD LOCK	1
5		OUTPUT HOLD DOWN ROD LOCK	1
6		ZONE 1 POP-UP CONVEYOR RAISE	1
7		ZONE 2 POP-UP CONVEYOR RAISE	1
1-7	2701955	MAC 82 SERIES ASSEMBLY	1
8	2701900	FILTER, REGULATOR, GAGE, AND LOCK OUT	1

Kalamazoo  
Packaing  
Systems  
Model #800FA  
Horizontal Winder Base  
w/ Motor Brake

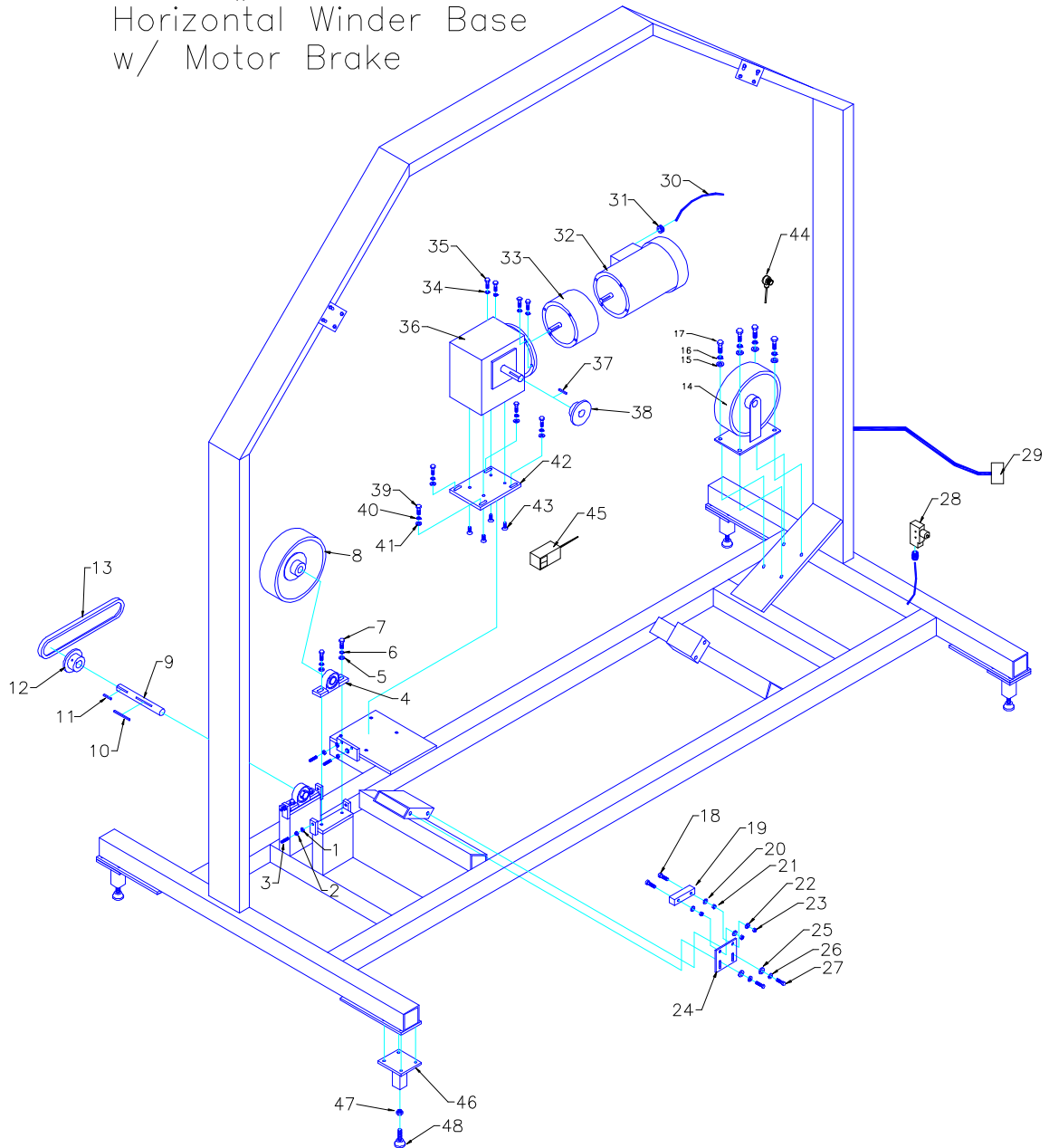

# PARTS MANUAL: 800V HORIZONTAL WINDER

ITEM	PART #	GRAINGER	DESCRIPTION	QTY
1	L48		5/16 USS WASHER	4
2	L47		5/16 LOCK WASHER	4
3	L54		5/16-18x 1-1/2" SET SCREW	4
4	1212500	5X692	1" PILLOW BLOCK BEARING	2
5	L65		3/8 USS WASHER	4
6	L64		3/8 LOCK WASHER	4
7	L83		3/8-16x 1-1/2" HEX HEAD CAP SCREW	4
8	1228090		10"x 3" DRIVE WHEEL w/ HUB	1
9	2502100		800 DRIVE SHAFT	1
10	L3		1/4"x 1/4"x 2-1/2" KEYWAY	1
11	L3		1/4"x 1/4"x 1" KEYWAY	1
12	1081140		DRIVEN SPROCKET (50BTL14)	1
12	1081310		BUSHING FOR ABOVE (1008x1")	1
13	1085000	6L074	# 50 CHAIN	1
14	1228000		10"x 3" IDLER WHEEL w/ TAPERED BEARINGS	1
15	L96		7/16 USS WASHER	4
16	L95		7/16 LOCK WASHER	4
17	L99		7/16-14 x 1-1/2" HEX HEAD CAP SCREW	4
18	L73		3/8-24 x 1-1/2" ALLEN HEAD CAP SCREW	16
19	2501000		800 SLIDE	8
20	L48		5/16 USS WASHER	16
21	L61		3/8-24 NYLOCK JAM NUT	16
22	L48		5/16 USS WASHER	16
23	L61		3/8-24 NYLOCK JAM NUT	16
24	2501010		800 SLIDE HOLDER	8
25	L65		3/8 USS WASHER	16

# PARTS MANUAL: 800V HORIZONTAL WINDER

ITEM	PARTS #	DESCRIPTION	QTY
26	L64	3/8 LOCK WASHER	16
27	L71	3/8-24x 1-1/4" HEX HEAD CAP SCREW	16
28	2108520	FILM DOOR LIMIT SWITCH	2
29	2103129	24-PIN HOOD STR.	1
29	2103131	^ PLUG 1-24 (see next page for pin numbers)	1
30	2099000	14/3 SJ CORD	1
31	2103400	CORD GRIP	1
32	105570R	3hp 230-460/3/60hz XEX MOTOR 145CT FACE	1
33	1073035	MOTOR BRAKE 480v 145TC	1
34	L64	3/8 LOCK WASHER	4
35	L80	3/8-16 x 1" HEX HEAD CAP SCREW	4
36	1066065T	5:1 R/A REDUCER 2.0CD 140C FACE (WINDER)	1
37	L3	1/4"x 1/4"x 1" KEYWAY	1
38	1081200	DRIVE SPROCKET (50BTL20)	1
38	1081330	BUSHING FOR ABOVE (1610x1-1/8")	1
39	L82	3/8-16 x 1-1/2" HEX HEAD CAP SCREW	4
40	L64	3/8 LOCK WASHER	4
41	L65	3/8 USS WASHER	4
42	860FA12-MM	800 MOTOR MOUNT	1
43	L50	5/16-18 x 1" FLAT HEAD	4
44	213180	RING HOME SENSOR	1
45	213261	CABLE FOR ABOVE	1
46	800-RFM	WINDER RUBBER FOOT MOUNT	4
47	L125	1/2-13 NUT	4
48	1228510	RUBBER FOOT	4
		OPTIONAL CASTERS AND FLOOR LOCKS	
	1222600	4" x 2" SWIVEL CASTER (NOT SHOWN)	4
	1222650	4" FLOOR LOCKS (NOT SHOWN)	4

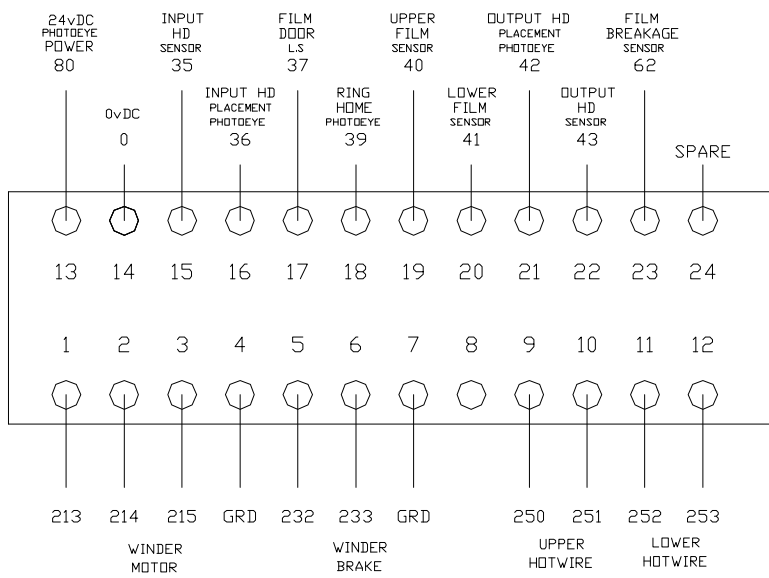

(B) WINDER  
24-PIN CONNECTOR

Kalamazoo Packaging Systems  
Model #862FA-D12  
DUAL 12" Variable Tension

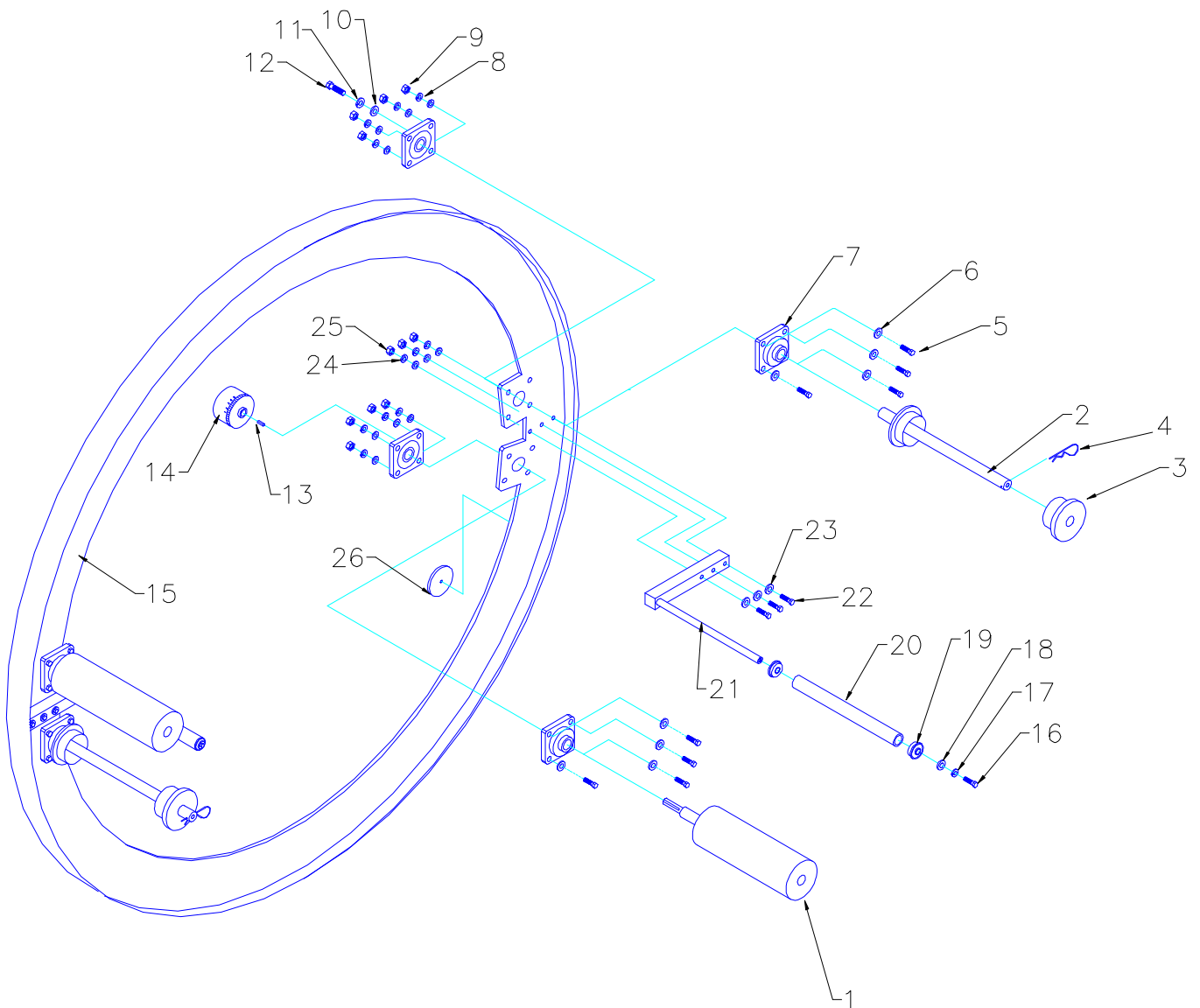

## PARTS MANUAL: 862FA-D12 WINDER RING

ITEM	PART/DWG.#	DESCRIPTION	QTY
1	623070	4" DIA. x 12" WINDER VARIABLE TENSION BRAKE ROLLER	2
2	623072	12" WINDER VARIABLE TENSION FILM HOLDER w/ PINED TOP CORE	2
3	623078	3" PLASTIC TOP CORE	2
4	623079	3/16" STEEL HITCH PIN CLIP	2
5	L102	7/16-20 x 2-1/4" HHCS	16
6	L97	7/16 SAE WASHER	32
7	121140	1" 4-BOLT FLANGE BEARING	8
8	L95	7/16 LOCK WASHER	16
9	L165	7/16-20 NYLOCK NUT	16
10	L111	1/2" USS WASHER	2
11	L110	1/2" LOCK WASHER	2
12	L128	1/2-13 x 1" HHCS	2
13	L2	3/16"x 3/16"x 3/4" KEYWAY	2
14	130550	5/8" FINISH BORE MAGNETIC BRAKE (MC 4)	2
15	862FA-D12-R	862FA-D12 DUAL FILM HEAD WINDER RING	1

## PARTS MANUAL: 860FA-12 WINDER RING

ITEM	PART #/DWG. #	DESCRIPTION	QTY
16	L51	5/16-18 x 1" HHCS	2
17	L47	5/16" LOCK WASHER	2
18	L48	5/16" USS WASHER	2
19	120600	5/8" I.D. x 1-3/8" O.D. FLANGED BEARING	4
20	537125	PVC 1-1/4" SCH. 40 TUBE x 13-3/8	2
21	623075	12" BRAKE IDLER ROLLER MOUNT	2
22	L57	5/16-18x 2" HHCS	6
23	L48	5/16 USS WASHER	12
24	L47	5/16" LOCK WASHER	6
25	L45	5/16-18 NYLOCK NUT	6
26	212383	3" PHOTO-EYE REFLECTOR	1

# Kalamazoo Packaging Systems PARTS MANUAL: 862FA-D12 FILM HOLDER and HOT WIRE

ITEM	DWG.# /PART #	DESCRIPTION	QTY
1	2701285	CUTTER CYLINDER 1-1/2" BORE x 24" STROKE	2
2	2701310	FILM CUTTER LIMIT SWITCH	2
3	2701320	FILM CUTTER LIMIT SWITCH BAND	2
4	862FA-D12-AFC-RCM	FILM CUTTER REAR CYLINDER MOUNT	2
5	862FA-D12-AFC-FCM	FILM CUTTER FRONT CYLINDER MOUNT	2
6	862FA-D12-AFC-HWB	HOT WIRE BRACKET	2
7	800-AFC-01	4 ROD CYLINDER FRONT PLATE	2
8		1/4"x 4-1/4"x 2-3/8" FOAM RUBBER	2
9	1310090	4-1/2" TUBE HOT WIRE	2
10	800071	5/8" TEFLON SHAFT x 16.0"	8
11	800-AFC-01	4 ROD CYLINDER END CAP	2
12	800-AFC-03	FILM CUTTER CYLINDER END CAP	2

Kalamazoo  
Packaging  
Systems  
Film Holder and Hotwire  
Model# 862FA-D12

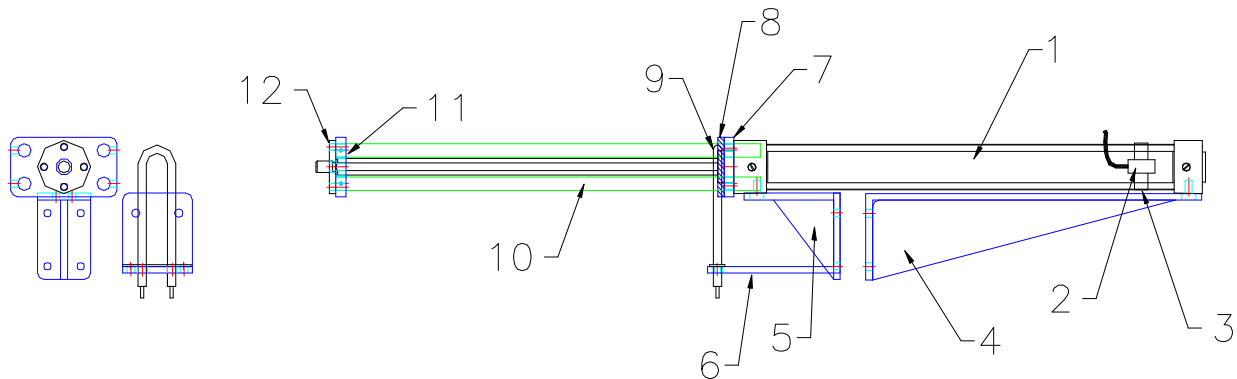

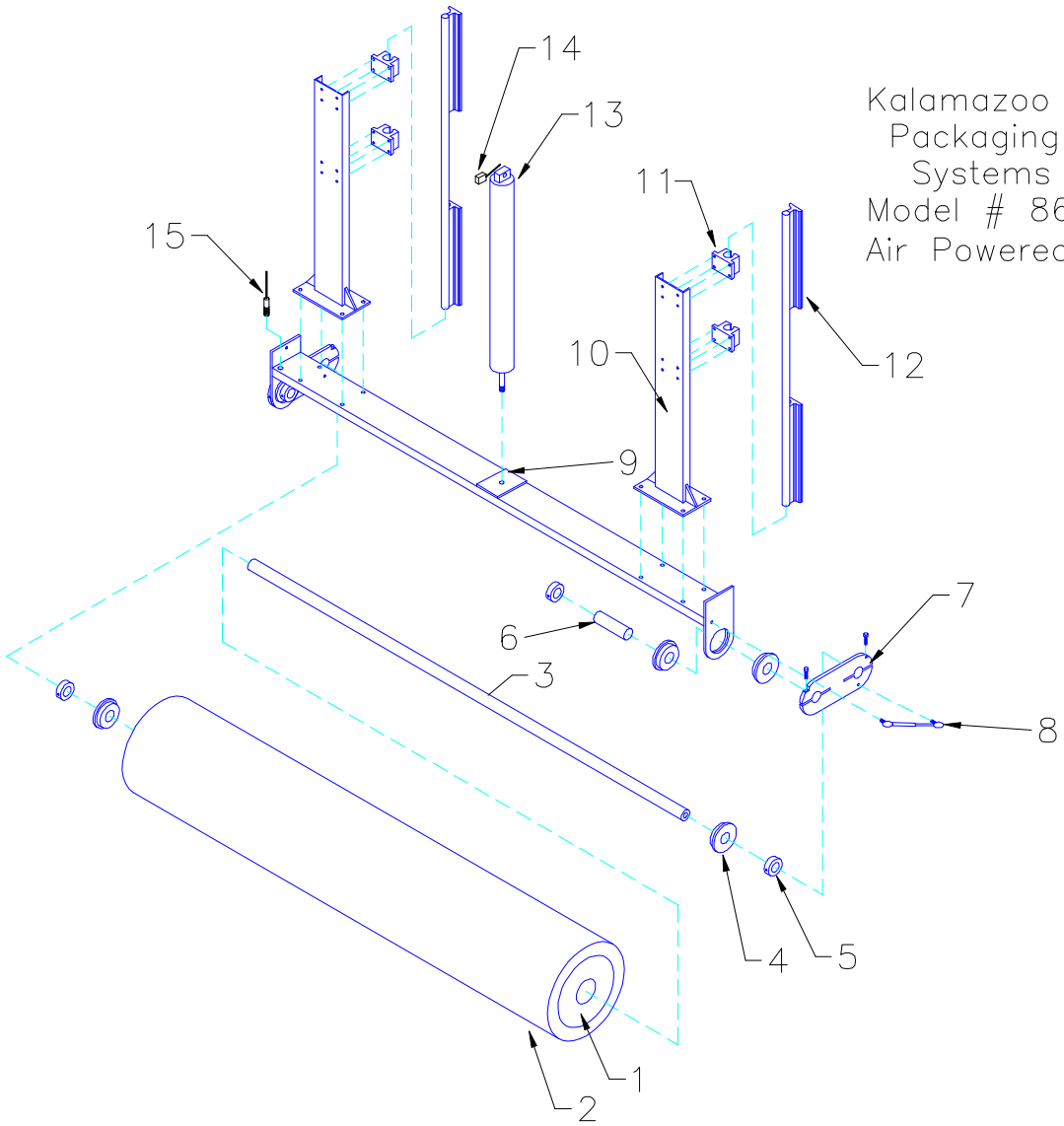

Kalamazoo  
Packaging  
Systems  
Model # 862FA-D12  
Air Powered Hold downs

**Kalamazoo Packaging Systems**  
**PARTS MANUAL: 862FA-D12**  
**HOLD DOWN ROLLER ASSEMBLY**

ITEM	DWG.# /PART #	DESCRIPTION	QTY
1	862FA-D12-HDRT	HOLD DOWN ROLLER TUBE	2
2	5380460	3-5/8" FOAM TUBE with GAFFERS TAPE	2
3	862FA-D12-HDRS	HOLD DOWN ROLLER SHAFT	2
4	1206000	5/8x 1-3/8 FLANGE BEARING	6
5	1215000	5/8" SHAFT COLLARS	4
6	5610000	5/8" G&P SHAFT x	2
7	862FA-D12-HDRPI	HOLD DOWN ROLLER PLATE (INPUT)	2
7	862FA-D12-HDRPO	HOLD DOWN ROLLER PLATE (OUTPUT)	2
8	6501015	7.01" GAS SPRING 15lb.	4
9	862FA-D12-HDRMA	HOLD DOWN ROLLER MOUNT ASSEMBLE	2
10	862FA-D12-HDRSCA	HOLD DOWN SLIDE CHANNEL ASSEMBLE	4
11	1212190	3/4" PILLOW BLOCK LINEAR BEARING (OPEN)	4
12	1211942	RAIL for 3/4" SHAFT (CUT IN HALF)	4
12	5612000	3/4" G&P SHAFT x 30"	4
13	2701540	2" BORE x 16" STR. ROD LOCK CYLINDER	2
14	2800055	SOLID STATE SWITCH	2
14	2800054	SWITCH BRACKET	2
15	2132000	BANNER 18mm BARREL SENSOR	2
15	2132010	BANNER 30' 4-PIN CABLE	2

Kalamazoo  
Packaging  
Systems  
MAIN CONSOLE

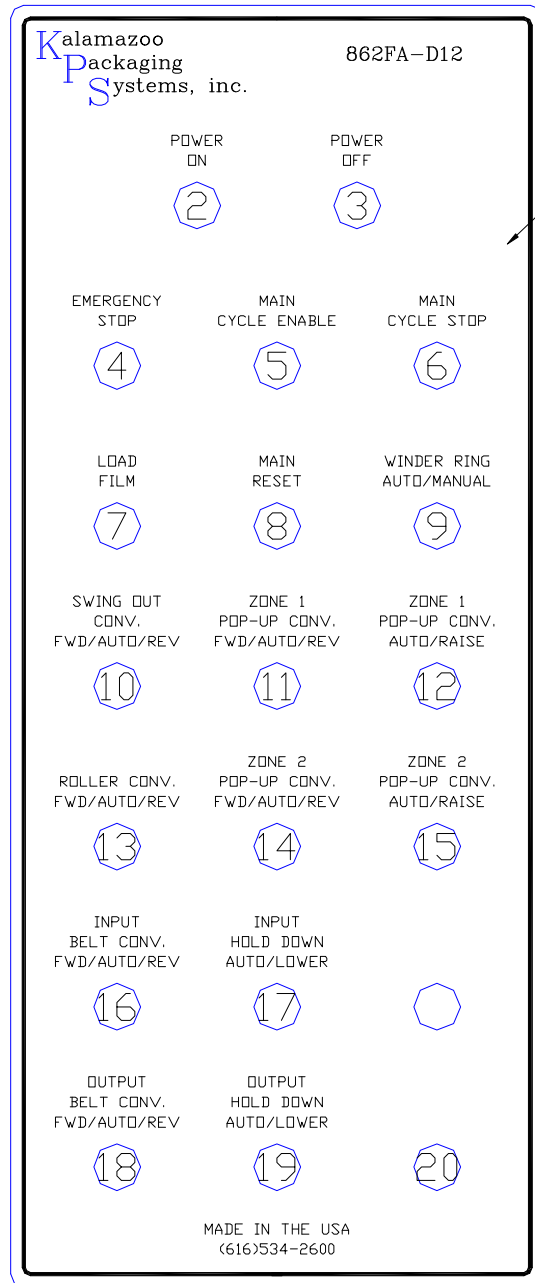

## PARTS MANUAL: 862FA-D12 MAIN CONTROL CONSOLE

ITEM	PART #	DESCRIPTION	QTY
1	D-862FA-D12	862FA-D12 MAIN CONTROL CONSOLE DECAL	1
2	2070690	GREEN LIGHTED PUSH BUTTON (POWER ON)	1
3	2070550	RED BUTTON (POWER OFF)	1
4	2071100	PUSH OFF/ TURN TO RESET (E-STOP)	1
5	2070010	GREEN PUSH BUTTON (MAIN CYCLE ENABLE)	1
6	2070550	RED PUSH BUTTON (MAIN CYCLE STOP)	1
7	2070560	BLUE PUSH BUTTON (FILM LOAD)	1
8	2070570	WHITE PUSH BUTTON (MAIN RESET)	1
9	2071000	2-POS. SELECTOR (WINDER AUTO/MANUAL)	1
10	2071030	3-POS. SELECTOR (SWING OUT CONV. FWD/AUTO/REV)	1
11	2071030	3-POS. SELECTOR (ZONE 1 POP-UP CONV. FWD/AUTO/REV)	1
12	2071000	2-POS. SELECTOR (ZONE 1 POP-UP CONV. AUTO/RAISE )	1
13	2071030	3-POS. SELECTOR (ROLLER CONV. FWD/AUTO/REV)	1
14	2071030	3-POS. SELECTOR (ZONE 2 POP-UP CONV. FWD/AUTO/REV)	1
15	2071000	2-POS. SELECTOR (ZONE 2 POP-UP CONV. AUTO/RAISE )	1
16	2071030	3-POS. SELECTOR (INPUT BELT CONV. FWD/AUTO/REV)	1
17	2071000	2-POS. SELECTOR (INPUT HOLD DOWN AUTO/LOWER )	1
18	2071030	3-POS. SELECTOR (OUTPUT BELT CONV. FWD/AUTO/REV)	1
19	2071000	2-POS. SELECTOR (OUTPUT HOLD DOWN AUTO/LOWER )	1
20	2079500	22mm SELECTOR KEY SWITCH (KEY #445)	1

# Kalamazoo Packaging Systems Model #862FA-D12 SUB PANEL LAYOUT

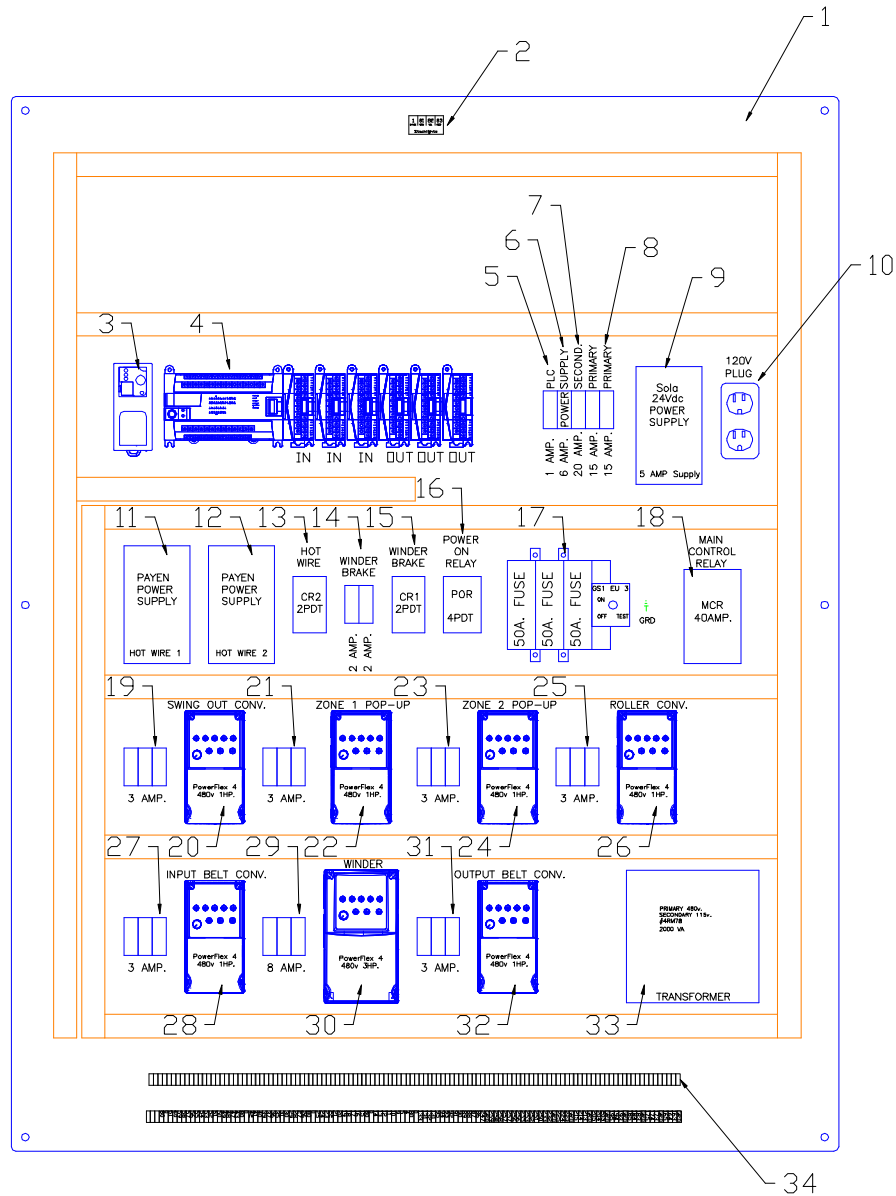

## PARTS MANUAL: 862FA-D12 SUBPANEL

ITEM	PART #	DESCRIPTION	QTY
1	A-60P48	SUB PANEL	1
2	209700	4 TERMINALS	1
3	2137026	A-B ETHERNET INTERFACE	1
3	2137025	2 METER HHT COMM. CABLE	1
4	2137207	A-B MICROLOGIX 1200	1
4	2137210	A-B 16 IN EXPANSION NODULE	3
4	2137220	A-B 16 RELAY OUT EXPANSION MODULE	3
5	2110110	1 AMP BREAKER (PLC)	1
6	2111610	6 AMP. BREAKER (SUPPLY)	1
7	2112010	20 AMP. BREAKER (SECONDARY)	1
8	2115020	15 AMP. 2-POLE BREAKER (PRIMARY)	1
9	2090800	TRANSFORMER 120ac IN/24Vdc OUT	1
10	2101550	110 VOLT OUTLET	1
11	1312010	PAYNE CONTROL (HOT WIRE 1)	1
12	1312010	PAYNE CONTROL (HOT WIRE 2)	1
13	208250	2PDT RELAY (HOT WIRE POWER)	1
13	208260	8-PIN BASE	1
14	2110420	2AMP. 2-POLE BREAKER (WINDER BRAKE)	1
15	208250	2PDT RELAY (WINDER BRAKE POWER)	1
15	208260	8-PIN BASE	1
16	208450	4PDT RELAY ( POWER ON RALEY)	1
17	2107450	MAIN FUSED DISCONNECT	1
17	2107452	EXTENSION SHAFT	1
17	2107484	50 amp. FUSE	3
18	208090	40 AMP MAIN CONTROL RELAY	1
19	2110330	3 AMP. 3-POLE BREAKER (SWING OUT CONV.)	1
20	1319010	A-B 1hp. AC DRIVE 480/3/60hz. (SWING OUT CONV.)	1

## PARTS MANUAL: 862FA-D12 SUBPANEL

ITEM	PART #	DESCRIPTION	QTY
19	2110330	3 AMP. 3-POLE BREAKER (SWING OUT CONV.)	1
20	1319010	A-B 1hp. AC DRIVE 480/3/60hz. (SWING OUT CONV.)	1
21	2110330	3 AMP. 3-POLE BREAKER (ZONE 1 POP-UP CONV.)	1
22	1319010	A-B 1hp. AC DRIVE 480/3/60hz. (ZONE 1 POP-UP CONV.)	1
23	2110330	3 AMP. 3-POLE BREAKER (ZONE 2 POP-UP CONV.)	1
24	1319010	A-B 1hp. AC DRIVE 480/3/60hz. (ZONE 2 POP-UP CONV.)	1
25	2110330	3 AMP. 3-POLE BREAKER (ROLLER CONV.)	1
26	1319010	A-B 1hp. AC DRIVE 480/3/60hz. (ROLLER CONV.)	1
27	2110330	3 AMP. 3-POLE BREAKER (INPUT BELT CONV.)	1
28	1319010	A-B 1hp. AC DRIVE 480/3/60hz. (INPUT BELT CONV.)	1
29	2110830	8 AMP. 3-POLE BREAKER (WINDER)	1
30	1319015	A-B 3hp. AC DRIVE 480/3/60hz. (WINDER)	1
31	2110330	3 AMP. 3-POLE BREAKER (OUTPUT BELT CONV.)	1
32	1319010	A-B 1hp. AC DRIVE 480/3/60hz. (OUTPUT BELT CONV.)	1
33	2091085	TRANSFORMER 480 IN/120 OUT (2000 KVA)	1
34	2097650	TERMINAL SINGLE SPRING LOADED	120
34	2097651	TERMINAL END COVER	2
34	2097652	TERMINAL END STOP	2
34	2097653	TERMINAL CLIP-ON NUMBER STRIPS	120

Kalamazoo  
Packaging  
Systems  
Model # 862FA-D12  
MAIN CONTROL CABINET

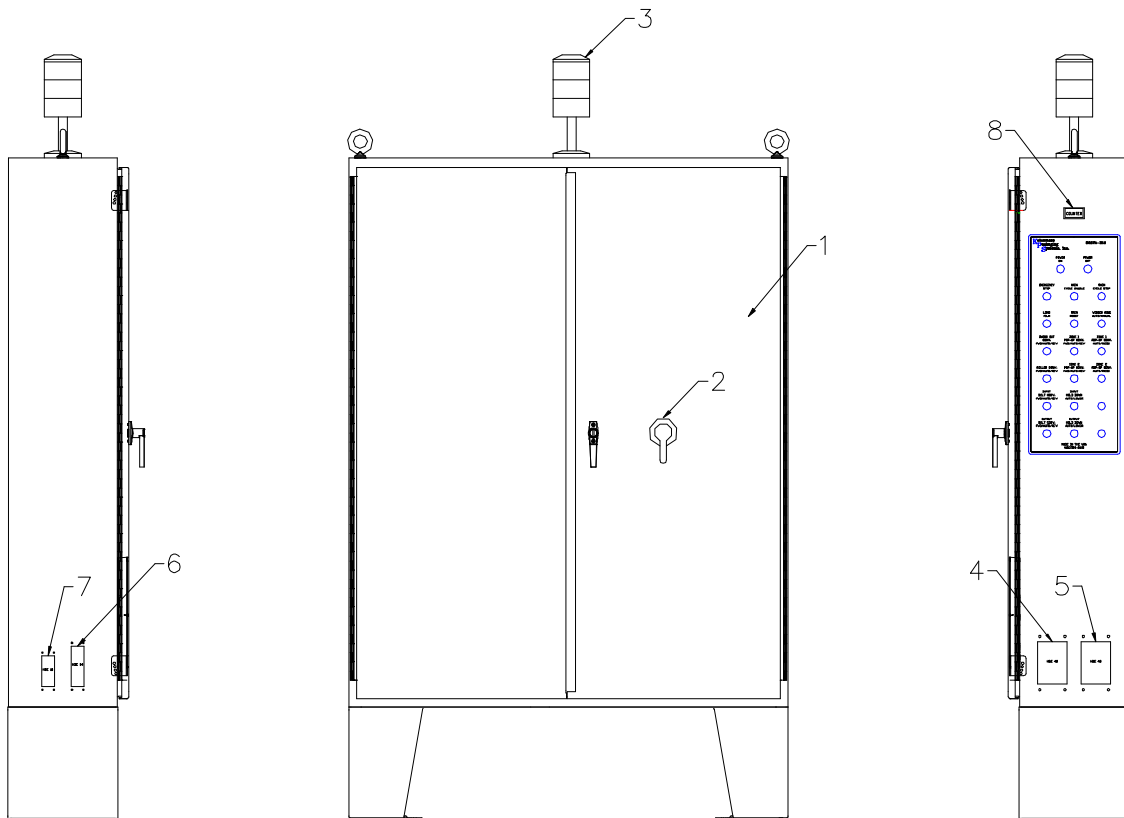

## PARTS MANUAL: 862FA-D12 MAIN CONTROL CABINET

ITEM	PART #	DESCRIPTION	QTY
1	A-604812LP	60"x 40"x 12" DEEP NEMA 12 ENCLOSURE	1
2	2107451	DISSCONNECT HANDLE	1
3	2064800	STACK LITE KIT 24Vdc (RED,YELLOW,GREEN)	1
3	2064860	REPLACEMENT BULB 24Vdc	
4	2103154	48-PIN BASE (A)	1
4	2103155	RECEPTACLE 1-24 (see next page for pin numbers)	1
4	2103156	RECEPTACLE 25-48 (see next page for pin numbers)	1
5	2103154	48-PIN BASE (B)	1
5	2103155	RECEPTACLE 1-24 (see page 63 for pin numbers)	1
5	2103156	RECEPTACLE 25-48 (see page 63 for pin numbers)	1
6	2103132	24-PIN BASE	1
6	2103133	RECEPTACLE 1-24 (see page 64 for pin numbers)	1
7	2103127	16-PIN BASE	1
7	2103128	RECEPTACLE 1-16 (see page 65 for pin numbers)	1
8	2122250	RESETTABLE WRAP COUNTER	1

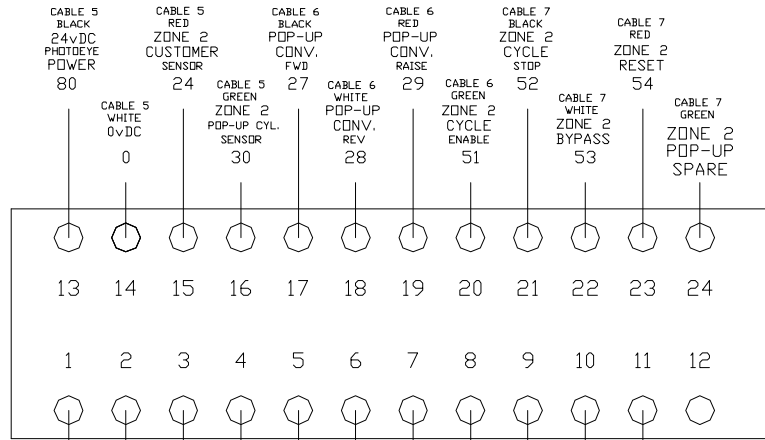

(A) INPUT SIDE  
48-PIN CONNECTOR  
PINS 1-24

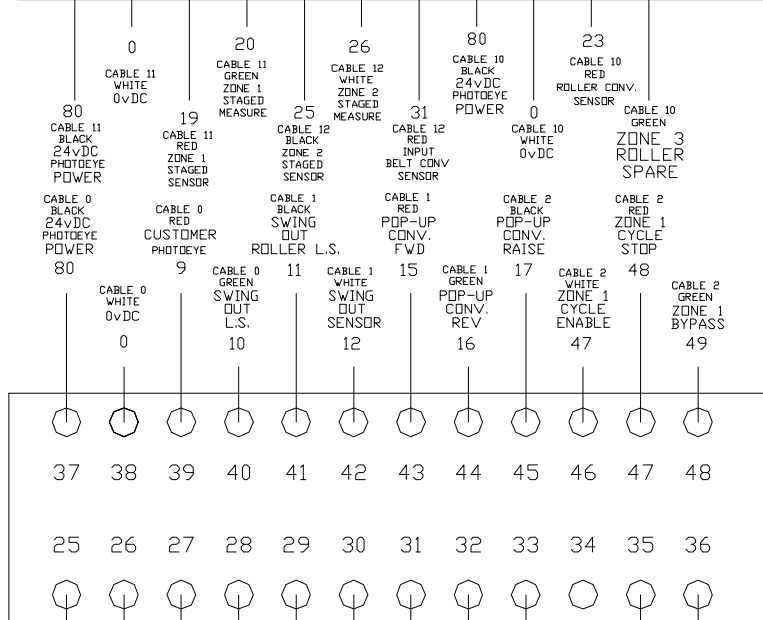

(A) INPUT SIDE  
48-PIN CONNECTOR  
PINS 25-48

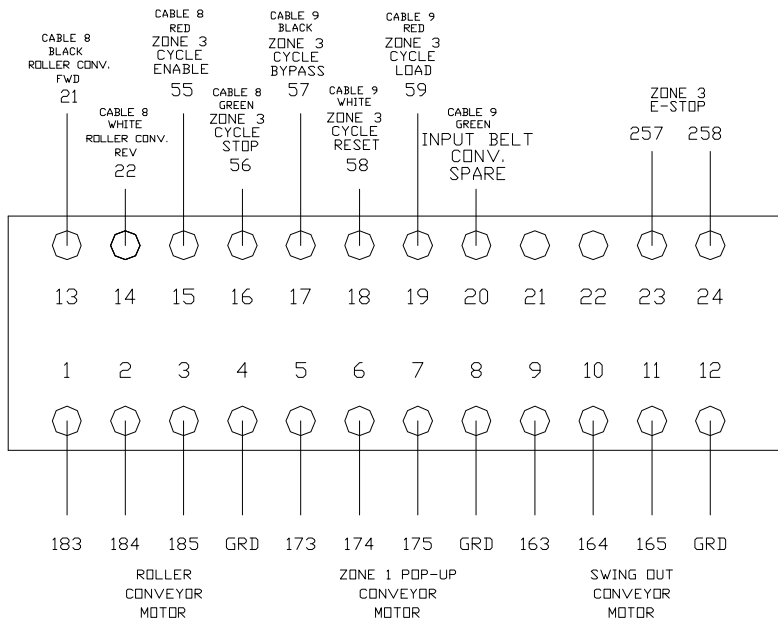

(B) INPUT SIDE  
48-PIN CONNECTOR  
PINS 1-24

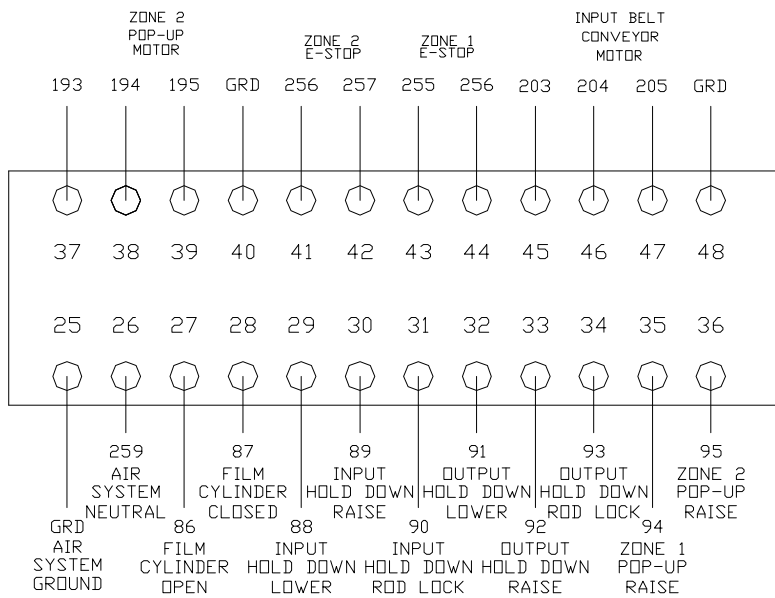

(B) INPUT SIDE  
48-PIN CONNECTOR  
PINS 25-48

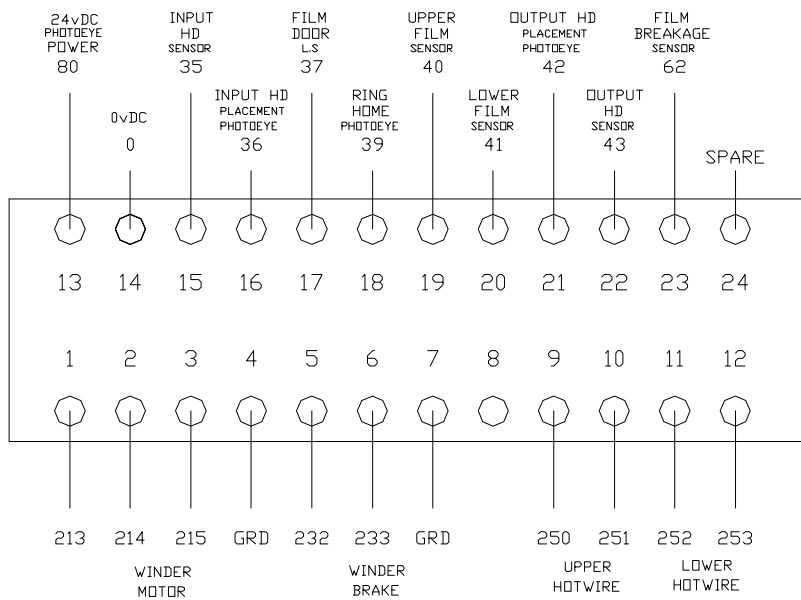

(B) WINDER  
24-PIN CONNECTOR

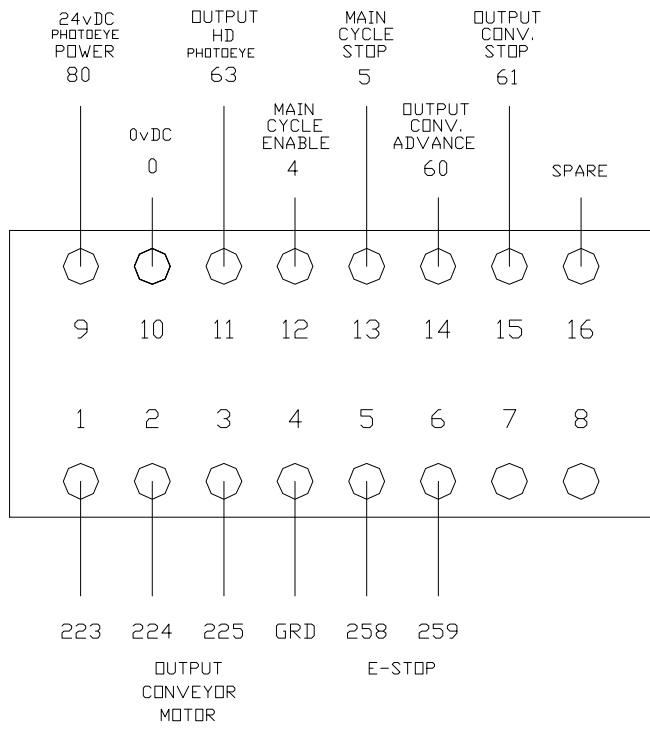

(A) OUTPUT CONVEYOR  
16-PIN CONNECTOR

Kalamazoo  
 Packaging  
 Systems  
 OUTPUT BELT CONVEYOR  
 Model # 862PB60-38.5TLC

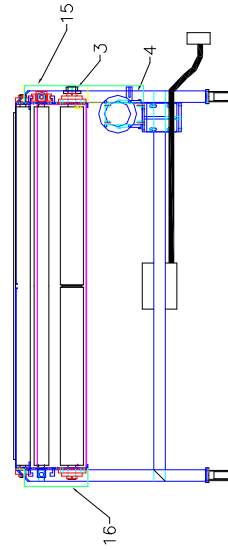
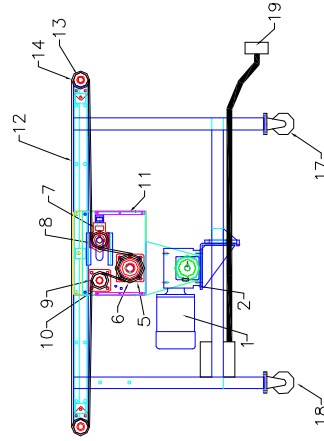
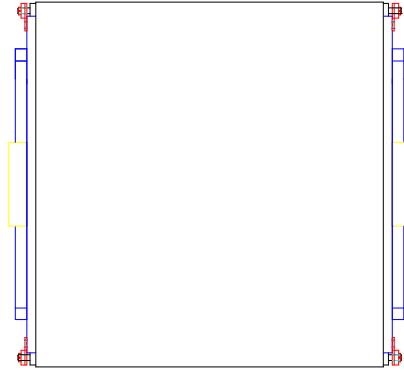

**Kalamazoo Packaging Systems**  
**PARTS MANUAL: OUTPUT BELT CONVEYOR**  
**862PB60-38.5TLC**

ITEM	DWG.# /PART #	DESCRIPTION	QTY
1	1055520	MOTOR	1
2	1063500T	R/A REDUCER	1
3	1080160-1.25	DRIVEN SPROCKET (50B16x1-1/4")	1
4	1080500	DRIVE SPROCKET (50B20x1")	1
5	1211500	1-1/4" 4-BOLT FLANGE BEARING	2
6	PB-862PB-4-1.25-DR	4" DRIVE ROLLER	1
7	PB-862-2.5TUR	2-1/2" TAKE-UP ROLLER	1
8	1210620	1" TAKE-UP BEARING	2
9	PB-862-2.5TUR	2-1/2" TAKE-UP ROLLER	1
10	1211400	1" 4-BOLT FLANGE BEARING	2
11	PB-DRC-62	DRIVE ROLLER END COVER	2
12	PB-60x60-BELT	860PB60 BELT (BLACK RUFF TOP)	1
13	1210540	1" CHEVRON BEARING	4
14	PB-862-2.5EIR	2-1/2" END IDLER ROLLER	2
15	PB-LDRG	DRIVE SIDE GUARD	1
16	PB-RDRG	DRIVEN SIDE GUARD	1
17	1222000	4" x 1-1/4" TOTAL LOCK SWIVEL CASTER	2
18	1222020	4" x 1-1/4" RIGID CASTER	2
19	2103125	16-PIN HOOD 90 DEGRESS	1
19	2103126	PLUG 1-16 (see next page for pin numbers)	1

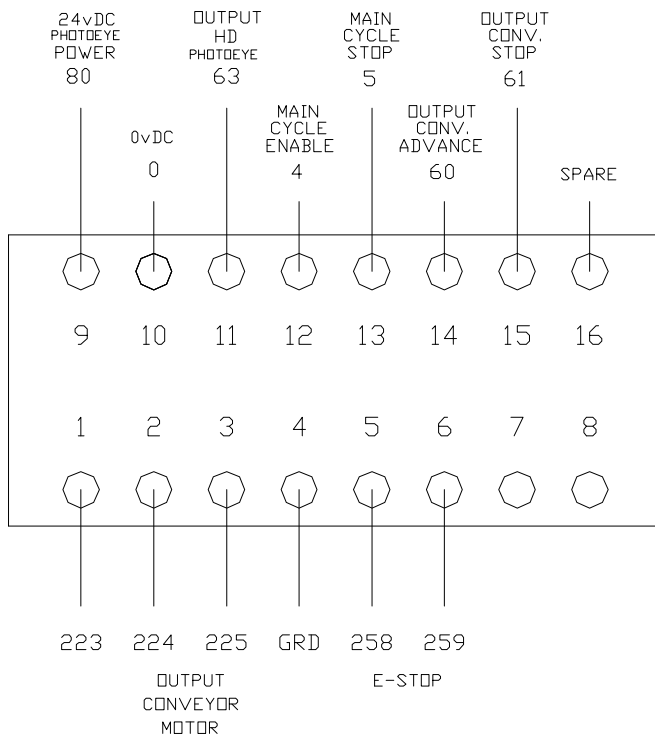

(A) OUTPUT CONVEYOR  
16-PIN CONNECTOR

Kalamazoo  
Packaging  
Systems  
ZONE 4 REMOTE CONSOLE

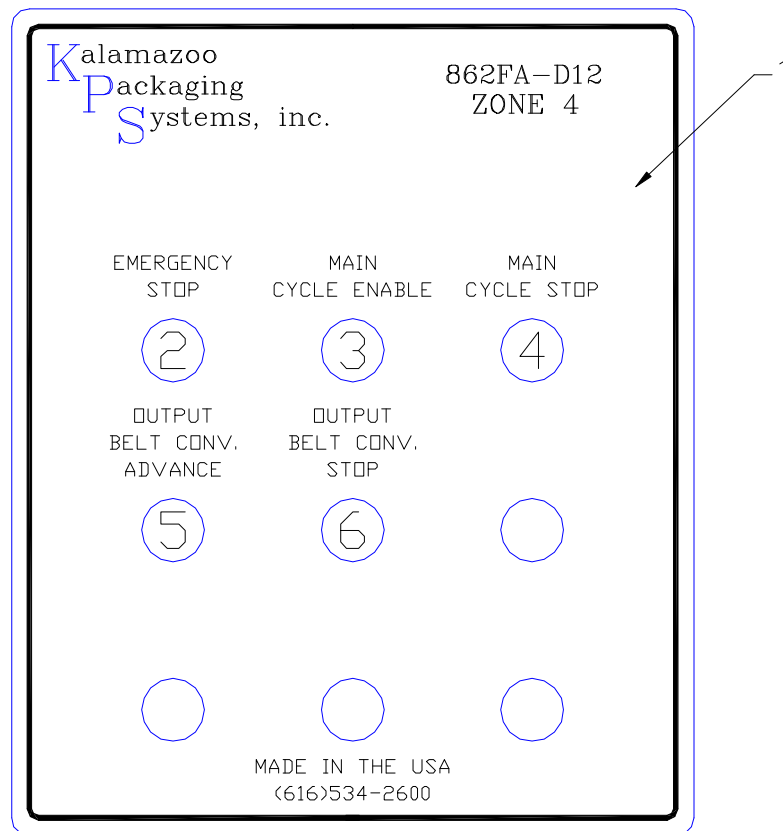

**Kalamazoo Packaging Systems**  
**PARTS MANUAL: ZONE 4 REMOTE CONSOLE**

ITEM	DWG.# /PART #	DESCRIPTION	QTY
1	D-862FA-D12-ZONE4	ZONE 4 REMOTE CONTROL DECAL	1
2	2071100	PUSH OFF/ TURN TO RESET (E-STOP)	1
3	2070010	GREEN PUSH BUTTON (MAIN CYCLE ENABLE)	1
4	2070500	RED MUSHROOM BUTTOM (MAIN CYCLE STOP)	1
5	2070600	BLACK PUSH BUTTON (OUPUT BELT CONV. ADVANCE)	1
6	2070550	RED PUSH BUTTON (OUTPUT BELT CONV. STOP)	1

# Kalamazoo Packaging Systems

## PARTS MANUAL: GRAVITY ROLLER CONVEYOR

ITEM	DWG.# /PART #	DESCRIPTION	QTY
1	1214480	1.9" DIA. ROLLER 27-1/2" BETWEEN FRAMES	20
2	1214500	30" WIDE x 120" LONG GRAVITY ROLLER FRAME	1
3	1214520	30" WIDE ADJUSTABLE FLOOR SUPPORT	2

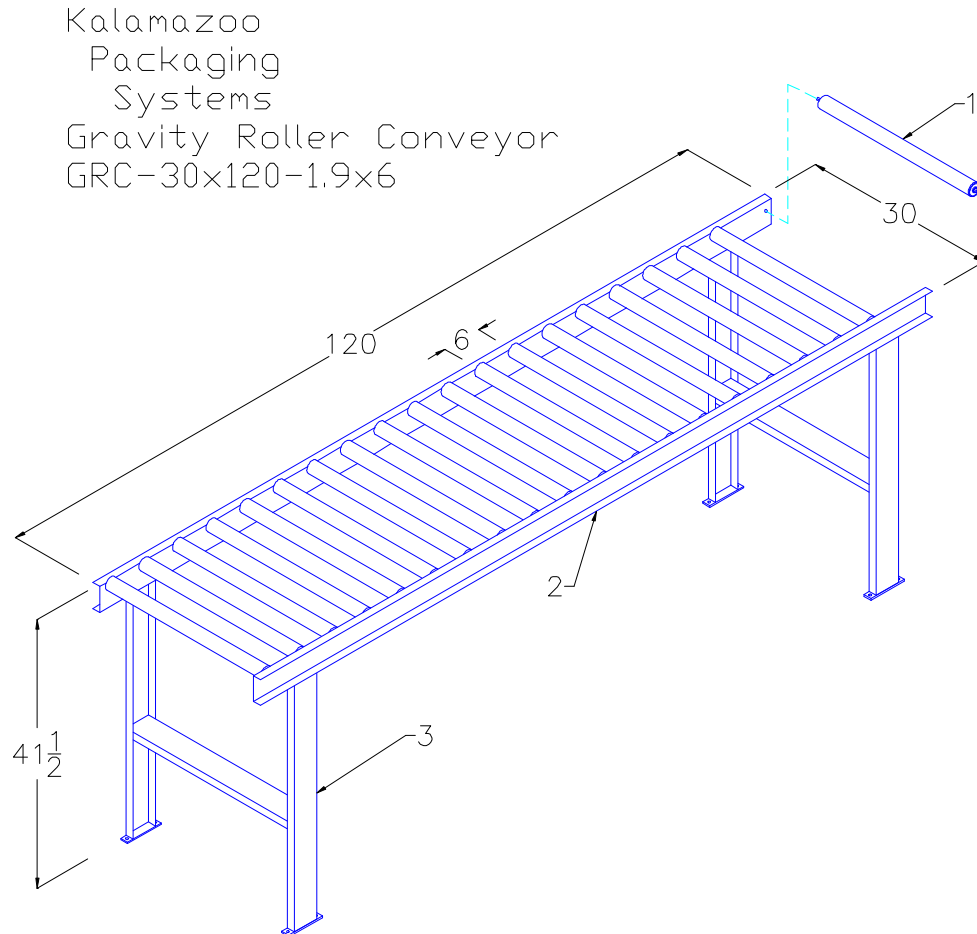





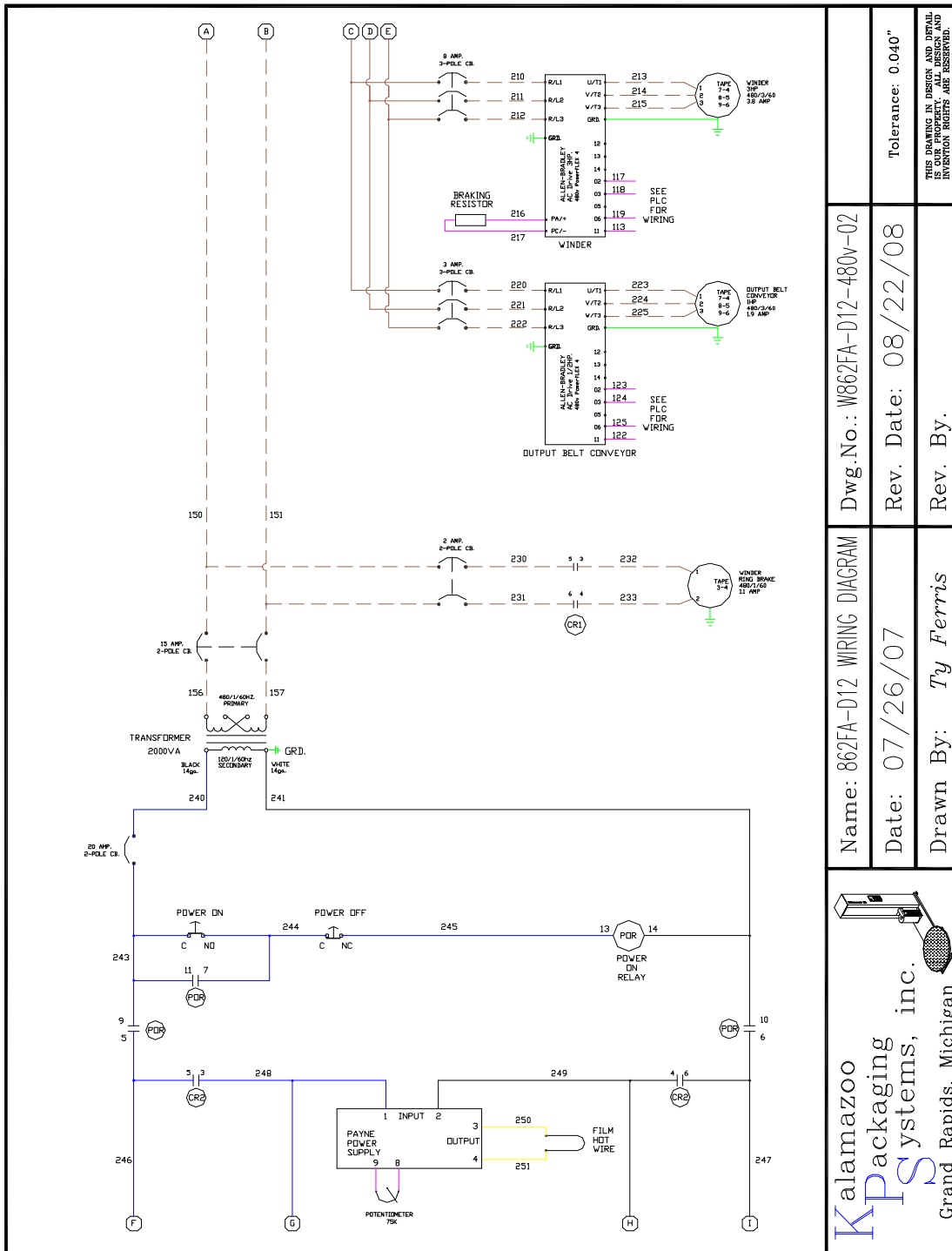

Name: 862FA-D12 WIRING DIAGRAM		Dwg.No.: W862FA-D12-480v-02	
Date: 07/26/07		Rev. Date: 08/22/08	
Drawn By: Ty Ferris		Rev. By:	
 <p>Kalamazoo Packaging Systems, inc. Grand Rapids, Michigan</p>		Tolerance: 0.040"	
		<small>THIS DRAWING IN DESIGN AND DETAIL IS THE PROPERTY OF KALAMAZOO PACKAGING SYSTEMS, INC. ALL RIGHTS ARE RESERVED.</small>	

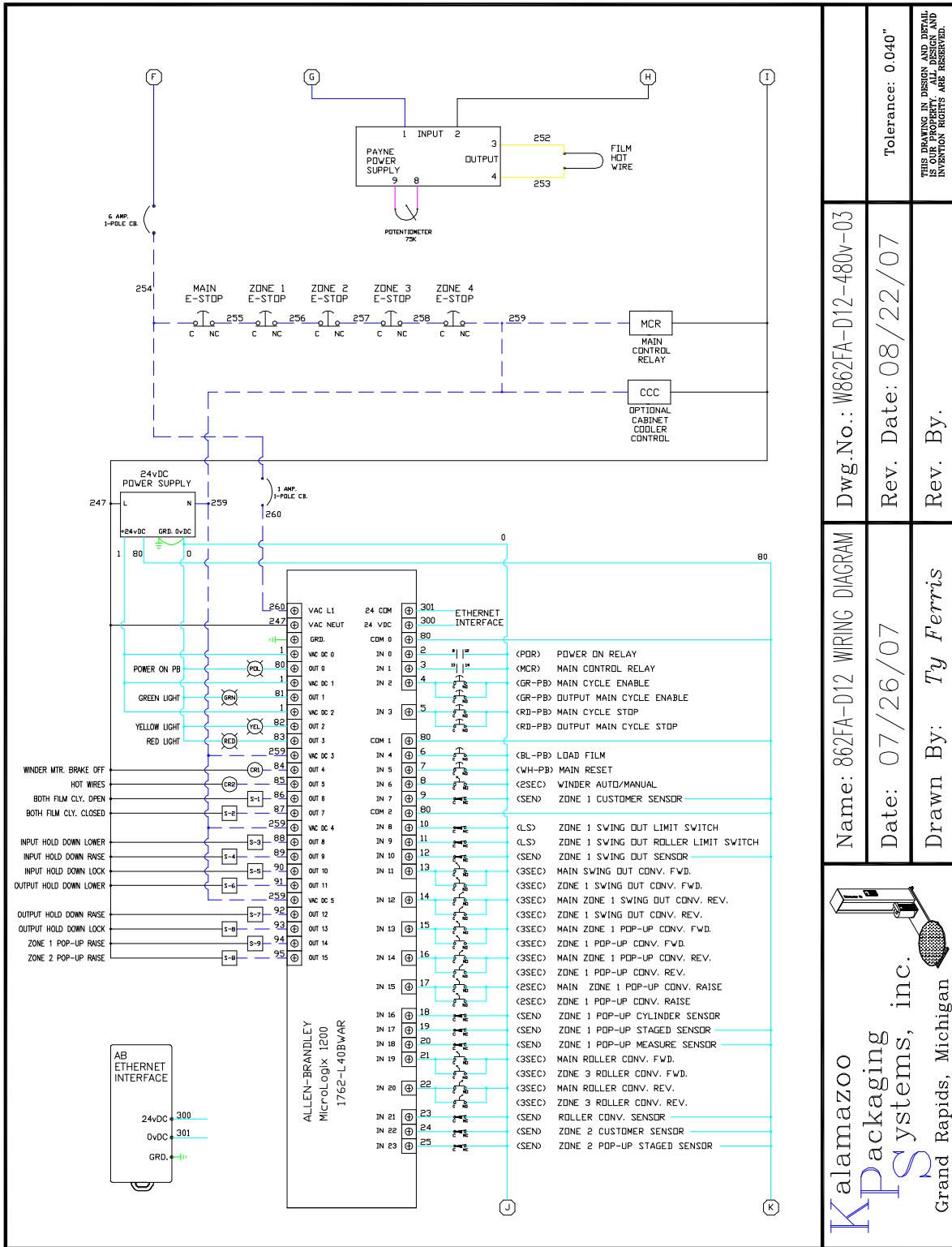

**Name:** 862FA-D12 WIRING DIAGRAM  
**Date:** 07/26/07  
**Drawn By:** Ty Ferris

**Dwg.No.:** W862FA-D12-480v-03  
**Rev. Date:** 08/22/07  
**Rev. By:**

**Tolerance:** 0.040"

THIS DRAWING IN DESIGN AND DETAIL IS THE PROPERTY OF KALAMAZOO PACKAGING SYSTEMS, INC. AND IS NOT TO BE REPRODUCED OR TRANSMITTED IN ANY FORM OR BY ANY MEANS, ELECTRONIC OR MECHANICAL, INCLUDING PHOTOCOPYING, RECORDING, OR BY ANY INFORMATION STORAGE AND RETRIEVAL SYSTEM.

**Kalamazoo Packaging Systems, inc.**  
 Grand Rapids, Michigan

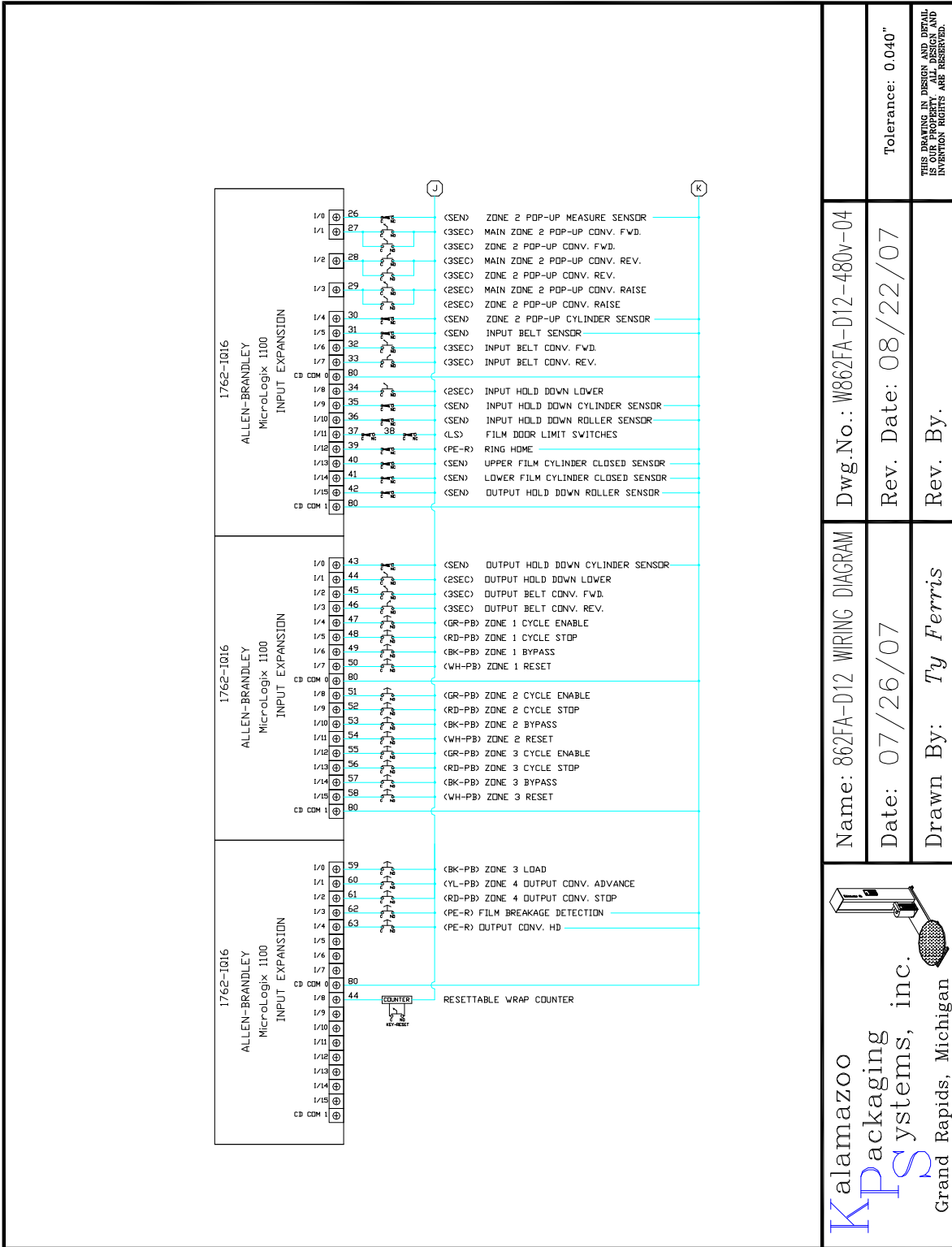

**Kalamazoo Packaging Systems, inc.**  
Grand Rapids, Michigan

Name: 862FA-D12 WIRING DIAGRAM  
Date: 07/26/07  
Drawn By: Ty Ferris

Dwg.No.: W862FA-D12-480v-04  
Rev. Date: 08/22/07  
Rev. By:

Tolerance: 0.040"

THIS DRAWING IN DESIGN AND DETAIL IS THE PROPERTY OF KALAMAZOO PACKAGING SYSTEMS, INC. AND IS NOT TO BE REPRODUCED OR TRANSMITTED IN ANY FORM OR BY ANY MEANS, ELECTRONIC OR MECHANICAL, INCLUDING PHOTOCOPYING, RECORDING, OR BY ANY INFORMATION STORAGE AND RETRIEVAL SYSTEM.



110v L1                    ———— 14ga. BLACK  
 110v L2                    ———— 14ga. WHITE  
 110v L1 CONTROLS      - - - - 16ga. BLACK  
 480v 10amp.              ———— 10ga. RED  
 480V MOTOR             - - - - 14ga. RED  
 DC CONTROLS            ———— 16ga. BLUE  
 DRIVES                    ———— 18ga. ORANGE  
 HOT WIRE                 ———— 10ga. YELLOW  
 GROUND                  ———— 10ga. GREEN

(LG-PB) LIGHTED GREEN PUSH BUTTON  
 (RD-PB) RED PUSH BUTTON  
 (RM-PB) RED MUSHROOM PUSH BUTTON  
 (GR-PB) GREEN PUSH BUTTON  
 (BK-PB) BLACK PUSH BUTTON  
 (WH-PB) WHITE PUSH BUTTON  
 (BL-PB) BLUE PUSH BUTTON  
 (2SEC) 2-POSITION SECELTOR  
 (3SEC) 3-POSITION SECELTOR  
 (LS) LIMIT SWITCH  
 (SEN) CYLINDER SENSOR  
 (PE-R) PHOTO-EYE RETROREFLECTIVE

PHOTO-EYE WIRING  
 42 BROWN  
 0 BLUE  
 SIGNAL WHITE

FILM CYLINDER SENSOR WIRING  
 42 BROWN  
 0 BLUE  
 SIGNAL BLACK

CONVEYOR LIFT CYLINDER SENSOR WIRING  
 0 BLUE  
 SIGNAL BROWN

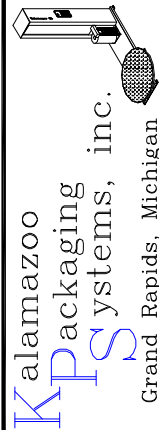

Name: 862FA-D12 WIRING DIAGRAM  
 Date: 07/26/07  
 Drawn By: Ty Ferris

Dwg.No.: W862FA-D12-480v-06  
 Rev. Date: 08/22/07  
 Rev. By.

Tolerance: 0.040"  
 THIS DRAWING IN DESIGN AND DETAIL IS OUR PROPERTY. ALL DESIGN AND INVENTION RIGHTS ARE RESERVED.

Print program from A-B 862FA-D12

# Kalamazoo

Packaging Systems



## **SERIES 862FA-D12** **FULLY-AUTOMATIC WINDER STRETCH** **WRAP SYSTEM WITH CONVEYORS**



# **OPERATOR** **MANUAL**

( Allen-Bradley PLC Program )  
Book 2 of 2