

Kalamazoo Packaging Systems

Division of Kal-Tek, Inc.

SUBJECT:

**820FA-12 Fully-Automatic Horizontal
Winder Stretch Wrap Systems with
12" Variable Tension Film Delivery
and Optional Conveyors.**



Shown with optional conveyors and casters.

DESCRIPTION:

A fully-automatic horizontal winder to wrap products with a maximum width of 21" and a minimum of 32" in length. The Winder will automatically start the film, wrap the product with stretch film for a predetermine amount of wraps and cut the film. 10-12" Kalamazoo variable tension film delivery.

All KPS Horizontal Winder are fully guarded with expanded metal.

Wrap Cycle:

Place the product onto the input conveyor and push the Cycle Start button or if the system is going to be put inline with other conveyors a sensor will automatic turn on the input conveyor. The input conveyor will come on a convey the product into the Winder. The Winder ring will start applying the film to the front edge of the product and the conveyors will come on and convey the product thought the Winder. The conveyors will stop and the Winder will apply the film to the tail end of the product. The Winder will automatic cut the film and the output conveyor will come back on and convey the product out of the Winder. End of cycle.

Specification:

Horizontal Winder: 1 hp. 230v ACTENV motor with a right angle gear reducer. Solid state variable speed controller. 0-65 RPM, friction wheel drive. Floor to center of ring 39-1/4"

Film Applicator: 10-12" Kalamazoo Variable Tension Film Delivery

With 12" Film at 65 RPM, this system will wrap 43' per minute.

With 20" film at 80 RPM, this system will wrap 100' per minute

Features:

Mitsubishi PLC.

Banner sensors.

Fully guarded.

Kalamazoo variable tension 10-12" film delivery.

Automatic film starting and cutting.

Automatic shut down when film door is open.

Direct fraction drive.

Computer design for smooth running and easy maintenance.

Available Options:

20" Variable tension film delivery

Single non-adjustable product fork.

Manual adjustable product forks.

Powered adjustable product forks.

Cabinet cooler

820P: 19" wide x 69.5" long powered roller conveyor,
rollers set on 6" centers.

820PC: Same conveyor as above with polyurethane covering.

820PB: 21" wide x 72" long powered belt conveyor.

12" V Style powered roller conveyor x 94" long

12" V Style powered roller conveyor x 94" long

with 1/8" Polyurethane Rollers Covers

Total lock swivel caster for conveyors

Caster and floor lock for winder

Custom color

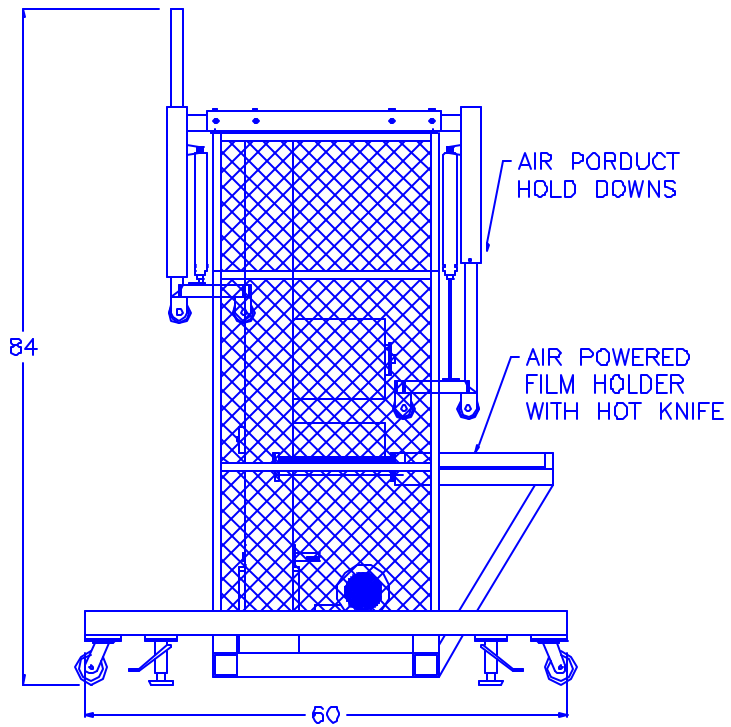

Kalamazoo
Packaging
Systems

Model# 820FA-12
Fully-Automatic
Horizontal Winder
Stretch Wrap System

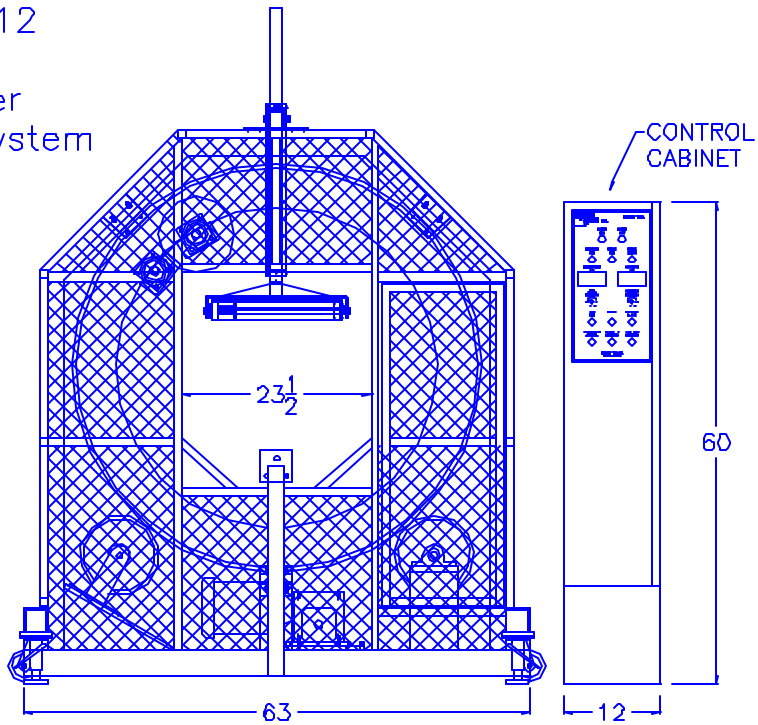

(SHOWN WITH OPTIONAL CASTERS & FLOOR LOCKS)