

Kalamazoo Packaging Systems

Division of Kal-Tek, Inc.

SUBJECT:

Kalamazoo Model 222C 4,000 lb. Powered Manual Horizontal Spiral Roll Wrapper.

Maximum roll = 96" Dia. x 83" Long

Minimum roll = 48" Dia. x 48" Long

Maximum weight = 4,000 lb.



DESCRIPTION:

4,000 lb. Capacity horizontal roll wrapper . Selector switch operated horizontal powered manual spiral film applicator (FORWARD/OFF/REVERSE). 30" Kalamazoo variable tension film delivery for 22.5" Diameter rolls. Selector switch operated 12" diameter product rollers (OFF/ON) .

Wrap Cycle:

Attach the film. Turn the Roller selector switch to ON, after the reinforcing wraps are applied turn the film carriage selector switch to Forward. When the film reaches the end of the roll return the film carriage switch to OFF and place the reinforcing wraps to the end of the roll. Turn the film carriage selector switch to Reverse. After the cycle is complete return the two switches to the OFF position.

FEATURES:

- Will accommodate loads up to 4,000 lb.
- Faster and easier than wrapping by hand.
- Model #222C Powered Manual Spiral accommodates varying length rolls.
- 5 hp. Variable speed AC roll drive motor with inline reducer
solid state AC variable speed drive.
- Roll drive roller 12" dia. 312 FPM
- 1 hp. Variable speed AC film carriage drive motor with solid state AC variable speed drive.
- Adjustable end limit switches.
- 30" Kalamazoo variable tension film delivery.
- Fork lift portability allows for easy placement throughout any facility.
- Limited lifetime warranty on all K.P.S. manufactured components.

Options:

Larger Film Rolls

Powered Pre-stretch Film Delivery

Extra Capacity

Extra Length

Semi-Automatic System

Fully-Automatic System

Product Hold Down

Product Stabilizer

Manual and Automatic Loading and/or Unloading of Product

Kalamazoo
Packaging
Systems
Model 222C
Horizontal Roll Wrapper

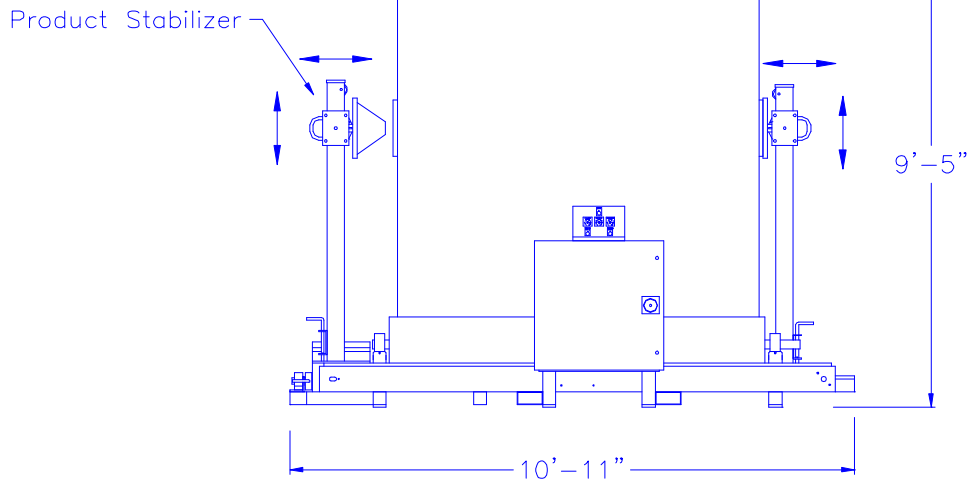

FRONT VIEW

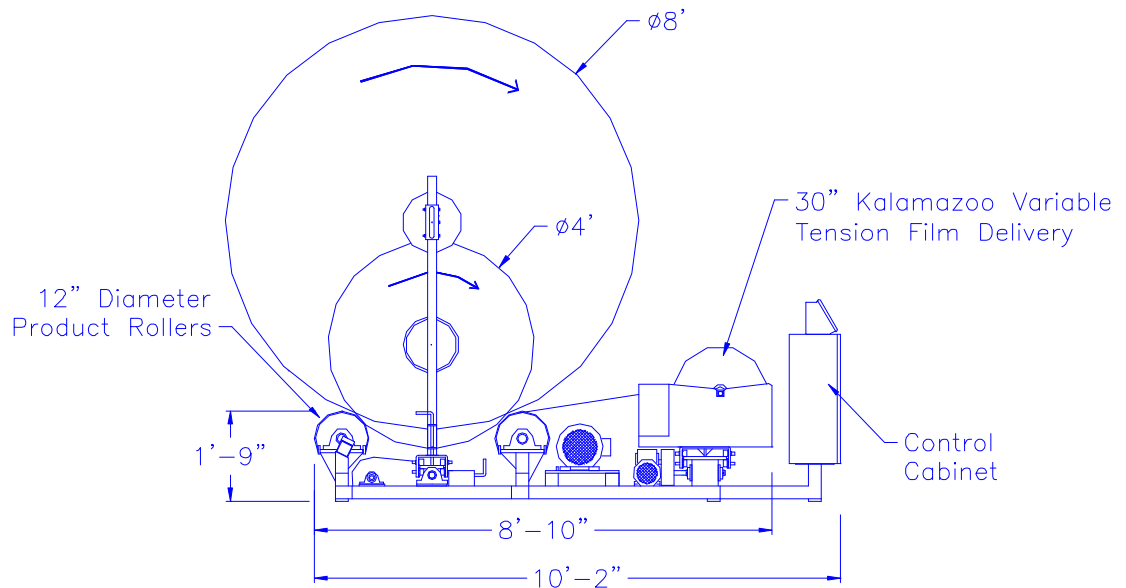

SIDE VIEW